

**VS FloPro 1.85 HP**  
VARIABLE-SPEED PUMP



**Jandy**<sup>®</sup>

**DUAL VOLTAGE.  
IDENTICAL PERFORMANCE.**



**VS FLOPRO™**  
VARIABLE-SPEED PUMP

# There's no need to sacrifice your pump's power.

The ideal replacement for high energy-consuming single-speed pumps up to 1.5 HP, the 115v/230v dual voltage VS FloPro™ 1.85 is *the only* variable-speed pump on the market that offers the same performance at both voltages.

## • 115v/230v Dual Voltage

With the ability to provide the same head pressure and flow rates at both 115v and 230v, the VS FloPro 1.85 eliminates the need for expensive main power rewiring without compromising performance.

## • Add iQPUMP01 for Instant Automation

Two auxiliary relays can be used to control other pool equipment, such as booster pumps and salt chlorinators, for easier installation and operation. No need for additional timeclocks!



## • Lower Electricity Costs

Save over \$850<sup>1</sup> per year in energy costs! The variable-speed motor allows for dramatic energy savings and quieter operation.

## • Our Quietest Variable-Speed Pump

Over 40% quieter<sup>2</sup> than other Jandy variable-speed pumps, the VS FloPro 1.85 HP features proprietary sound dampening motor technology allowing it to operate with noticeably less noise.

## • Choose Your Own Controller

Designed to work with the following Jandy® control systems for complete programmability and customization (controller sold separately):

- › Jandy AquaLink® Automation Systems
- › iQPUMP01 with iAquaLink® App Control
- › JEP-R Controller

## • Additional Features

- › Adjustable base for seamless direct replacement of a variety of other pumps in the aftermarket
- › Zero Clearance TEFC Motor for cool, quiet operation in tight spaces
- › 2" unions included or utilize 2" internal threads
- › Easy Controller Setup auto detects connection to an automation system or a traditional controller, eliminating the need to adjust settings manually
- › RS485 Quick Connect Port for faster installation and maintenance
- › Dry Contact Relay Control
- › Tool-free lid for easy debris removal
- › Ergonomic easy-transport handle

## ADJUSTABLE BASE CONFIGURATIONS<sup>3</sup>

Base	Fits	'A' Dimension	'B' Dimension
No Base	Hayward® Super Pump® Pentair® SuperFlo® Sta-Rite® SuperMax®	7 3/4"	12 3/4"
Small Base	Hayward Super II™ Jandy PlusHP and MaxHP Pumps	8 7/8"	13 7/8"
Small Base w/ Spacers	Pentair WhisperFlo® Sta-Rite Dyna-Glas™	9 1/8"	14 1/8"
Small Base + Large Base	Sta-Rite Max-E-Pro® Sta-Rite Dura-Glas® Sta-Rite Dura-Glas II Sta-Rite Max-E-Glas®	10 3/4"	15 3/4"

## DIMENSIONS

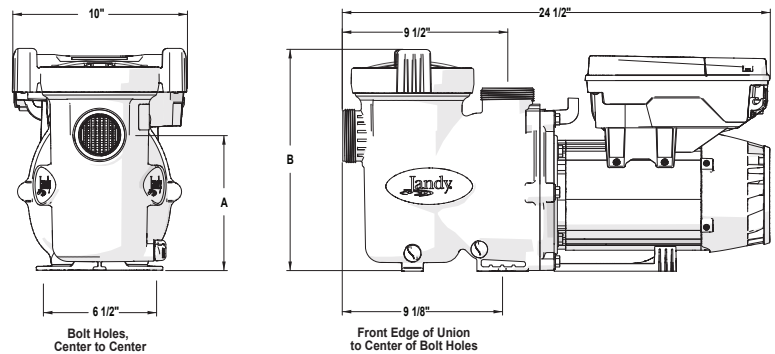

## SPECIFICATIONS

Model No.	THP	WEF <sup>4</sup>	Voltage	Max Watts	Amps	Union Size	Rec. Pipe Size <sup>5</sup>	Carton Weight	Overall Length
VSFHP185DV2A	1.85	8.5	230 VAC 115 VAC	1,700W 1,800W	7.5 15.5	2" x 2"	1 1/2" - 2 1/2"	53 lbs.	24 1/2"

## PERFORMANCE

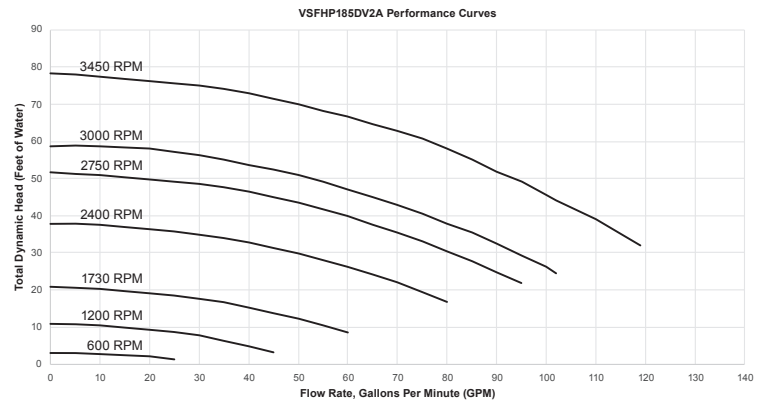

<sup>1</sup> Based on a 22,500 gallon pool with two turnovers per day at an energy cost of \$0.195/kWh vs. comparable single speed pumps; when tested in accordance with the applicable requirements of 10 CFR 429.

<sup>2</sup> When compared to the average dB reading of other Jandy variable-speed pumps at 3450 RPM from 6 ft., based on third-party independent lab sound testing.

<sup>3</sup> Small base with spacers included with all FloPro pumps. Large base is optional part R0546400.

<sup>4</sup> WEF = weighted energy factor in kcal/kWh. WEF is a performance-based metric adopted by the Department of Energy to characterize the energy performance of dedicated-purpose pool pumps. Department of Energy 10 CFR Parts 429 and 431.

<sup>5</sup> Always follow local building and safety codes for pipe sizing and guidelines.

Jandy.com | 1.800.822.7933

©2021 Zodiac Pool Systems LLC. All rights reserved. ZODIAC® is a registered trademark of Zodiac International, S.A.S.U., used under license. All other trademarks are the property of their respective owners. 9967\_SL

