

# Model E71-II VHV



Non Self-Priming Dual Voltage  
Variable Speed Pool Pump

## Features

- This high performance, medium head pump comes complete with an industry standard Carbon/Ceramic 5/8" mechanical seal for convenient replacement.
- Non-corrosive, chemical/UV resistant, and can withstand temperatures of up to 150°F.
- Horizontal/Vertical discharge in one casing.
- Suction and discharge ports are equipped with hose adaptors and 1.5" NPT. (Also available with 1.5" Slip quick disconnect unions)
- Specially constructed clear lid with ring lock design is easy to open. Large strainer basket is always locked in place.
- Reusable o-rings throughout.
- Pump has a standard 3 ft. 3/12 AWG cord set pre-mounted. A variety of other cord sets are available.
- Every pump is performance tested before leaving the Speck factory.

## Features Specific to the 1.1 THP Dual Voltage Motor

- Pump is equipped with a 1.1 THP (48 frame thru-bolt mount) Variable Speed Motor.
- Motor runs on a wide voltage range 100-130/200-250V. Automatically detects 115 or 230V.
- Built-In Controller, LED Screen & Keypad can be locked for safety.
- 3 Adjustable Power Levels - Levels can be set to range from 50 Watts/1000 RPM to 1000 Watts/3500 RPM (in increments of 10 Watts).
- Programmable high efficiency TEFC (totally enclosed fan cooled) maintenance free permanent magnet brushless 48 frame motor.

## Dimensional Drawing

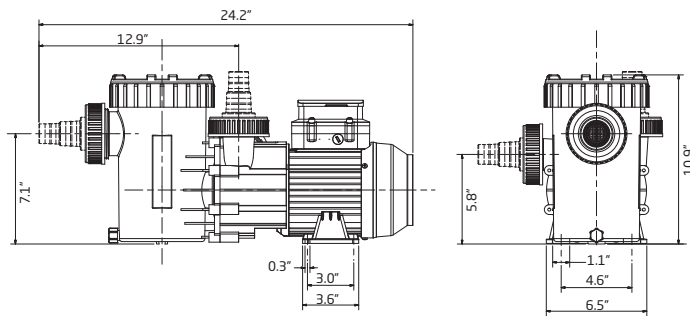

## Technical Data

| Order #         | Model #    | THP | WEF  | Volts   | Motor/Frame | Cord Set      | List Price |
|-----------------|------------|-----|------|---------|-------------|---------------|------------|
| AG195-V100T-OST | E71-II VHV | 1.1 | 10.3 | 115-230 | TEFC/48     | 3' standard   | \$1,001.00 |
| AG195-V100T-OTL | E71-II VHV | 1.1 | 10.3 | 115-230 | TEFC/48     | 3' twist-lock | 1,001.00   |



Model E71-II VHV



(top view)



(side view)

## Trademarks and Certifications



## Performance Curves

