

EnergyRite®

Pool & Spa Heater

Service Manual

Models: ER152, ER202,
ER252, ER302, and ER402



 **Lochinvar®**
High Efficiency Water Heaters, Boilers and Pool Heaters

⚠ WARNING

This manual must only be used by a qualified heating installer / service technician. Read all instructions, including this manual and the EnergyRite Installation and Operation Manual, before installing. Perform steps in the order given. Failure to comply could result in severe personal injury, death, or substantial property damage.

Save this manual for future reference.

Contents

Contents	2
Hazard definitions	2
Please read before proceeding	3
What is in this manual?	5
1. Service	6
General Operation	9
Access Setup Menu	10
Access Service Menu	11
2. Maintenance	13
Burner removal and cleaning	15
Heat exchanger cleaning	17
Combustion air shutter adjustment	18
Facts about water chemistry	20
Heat exchanger inspection	21
Prevention of freezing	21
Winterizing	21
3. Troubleshooting	22
Troubleshooting Chart - No Display	22
Checking temperature sensors	23
Troubleshooting Chart - Noisy System	24
Troubleshooting Chart - Fault Messages	25
Gas Manifold Pressure Adjustment Procedure	28
Checking Gas Supply Pressure	30

Hazard definitions

The following defined terms are used throughout this manual to bring attention to the presence of hazards of various risk levels or to important information concerning the life of the product.

⚠ DANGER

DANGER indicates an imminently hazardous situation which, if not avoided, will result in death or serious injury.

⚠ WARNING

WARNING indicates a potentially hazardous situation which, if not avoided, could result in death or serious injury.

⚠ CAUTION

CAUTION indicates a potentially hazardous situation which, if not avoided, may result in minor or moderate injury.

CAUTION

CAUTION used without the safety alert symbol indicates a potentially hazardous situation which, if not avoided, may result in property damage.

NOTICE

NOTICE indicates special instructions on installation, operation, or maintenance that are important but not related to personal injury or property damage.

Please read before proceeding

⚠ WARNING

Installer – Read all instructions, including this manual and the EnergyRite Installation and Operation Manual, before installing. Perform steps in the order given.

User – This manual is for use only by a qualified heating installer/service technician. Refer to the EnergyRite User's Information Manual for your reference.

Have this pool heater serviced/inspected by a qualified service technician at least annually.

Failure to comply with the above could result in severe personal injury, death or substantial property damage.

NOTICE

When calling or writing about the pool heater – Please have the pool heater model and serial number from the pool heater rating plate.

Consider piping and installation when determining pool heater location (see the EnergyRite Installation and Operation Manual).

Any claims for damage or shortage in shipment must be filed immediately against the transportation company by the consignee.

Handling ceramic fiber materials

REMOVAL OF COMBUSTION CHAMBER LINING

⚠ WARNING

The combustion chamber insulation in this product contains ceramic fiber material. Ceramic fibers can be converted to cristobalite in very high temperature applications. The International Agency for Research on Cancer (IARC) has concluded, "Crystalline silica inhaled in the form of quartz or cristobalite from occupational sources is carcinogenic to humans (Group 1).":

- Avoid breathing dust and contact with skin and eyes.
 - Use NIOSH certified dust respirator (N95). This type of respirator is based on the OSHA requirements for cristobalite at the time this document was written. Other types of respirators may be needed depending on the job site conditions. Current NIOSH recommendations can be found on the NIOSH website at <http://www.cdc.gov/niosh/homepage.html>. NIOSH approved respirators, manufacturers, and phone numbers are also listed on this website.
 - Wear long-sleeved, loose fitting clothing, gloves, and eye protection.
- Apply enough water to the combustion chamber lining to prevent airborne dust.
- Remove the combustion chamber lining from the pool heater and place it in a plastic bag for disposal.
- Wash potentially contaminated clothes separately from other clothing. Rinse clothes washer thoroughly.

NIOSH stated First Aid.

- Eye: Irrigate immediately.
- Breathing: Fresh air.

Please read before proceeding

When servicing pool heater –

- To avoid electric shock, disconnect electrical supply before performing maintenance.
- To avoid severe burns, allow the pool heater to cool before performing maintenance.

Pool heater operation –

- Do not block flow of combustion or ventilation air to the pool heater.
- Should overheating occur or gas supply fail to shut off, do not turn off or disconnect electrical supply to circulator. Instead, shut off the gas supply at a location external to the appliance.
- Do not use this pool heater if any part has been under water. The possible damage to a flooded appliance can be extensive and present numerous safety hazards. Any appliance that has been under water must be replaced.

Pool heater water –

- Do not use petroleum-based cleaning or sealing compounds in the pool heater system. Gaskets and seals in the system may be damaged. This can result in substantial property damage.
- Do not use “homemade cures” or “pool heater patent medicines”. Serious damage to the pool heater, personnel, and/or property may result.

What is in this manual?

Service

The EnergyRite display

- Display panel readout, buttons and their functions

Control module inputs

- Control module inputs and options

Control module outputs

- Control module outputs and options

General

- How the pool heater operates
- How the control module operates

Control panel menu access

- Accessing service and setup mode and locating menus

Maintenance

- Service and maintenance schedules
- Inspect pool heater area and pool heater interior
- Check all piping for leaks
- Check air openings
- Flue vent system and air piping
- Check water system
- Check pool heater relief valve (if applicable)
- Inspect ignition electrode
- Check ignition ground wiring
- Check all pool heater wiring
- Check control settings
- Perform start-up and checks
- Check burner flame
- Check flame signal
- General maintenance
- Cleaning heat exchanger

Troubleshooting

- Troubleshooting table - No display
- Checking temperature sensors
- Sensor table
- Troubleshooting table - Fault messages displayed on pool heater interface
- Gas manifold pressure adjustment procedure
- Checking gas supply pressure

1 Service

The EnergyRite display

- Hold for 5 seconds to enter Service Mode
- Press to exit Setup and Service Mode

- Hold for 5 seconds to enter Setup Mode
- Press to cycle through the menus in Setup Mode

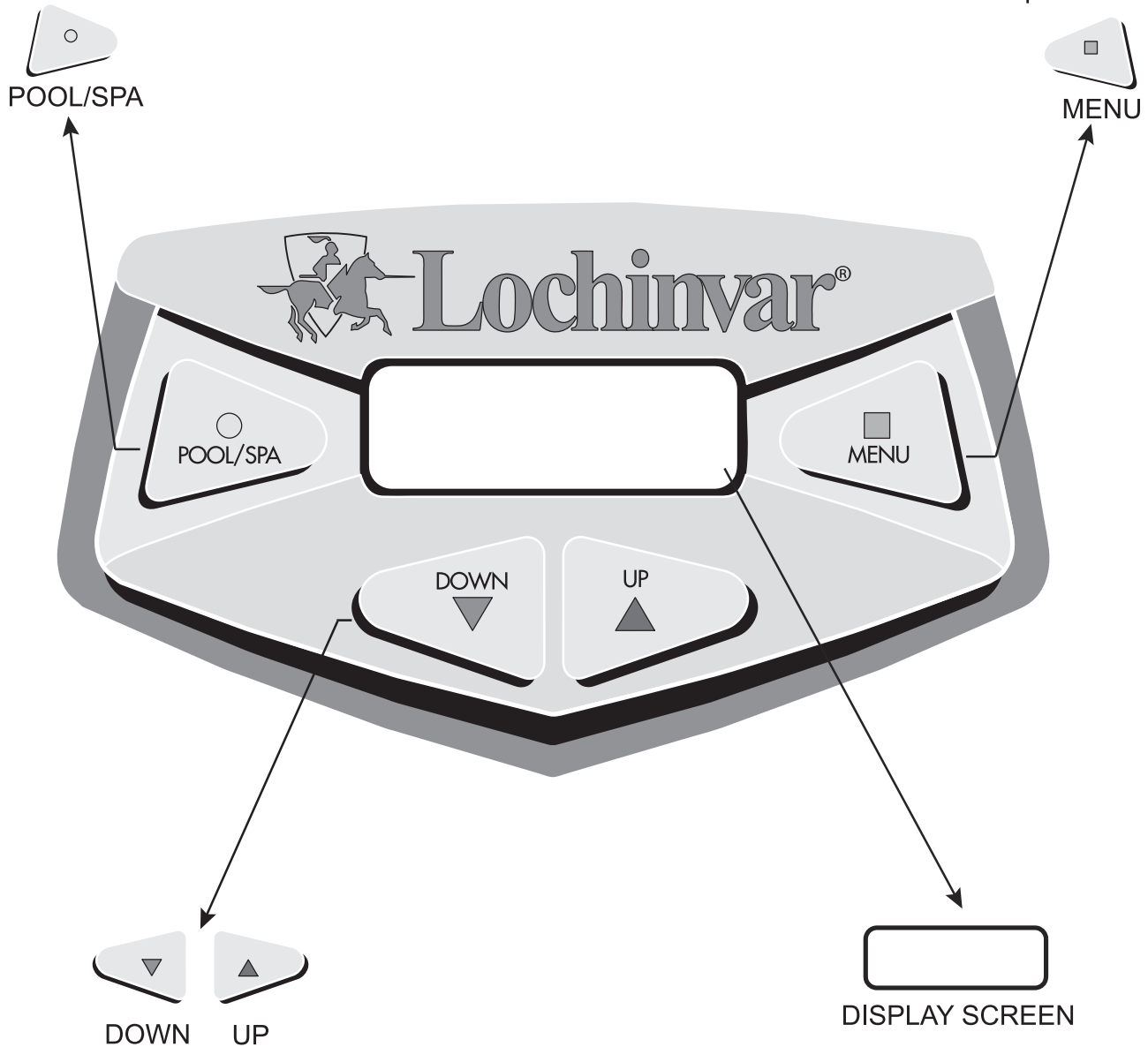

- Press to change pool heater water temperature set point during normal operation
- Press to navigate through Service Mode
- Press to change values in Setup Mode

1 Service *(continued)*

Control inputs

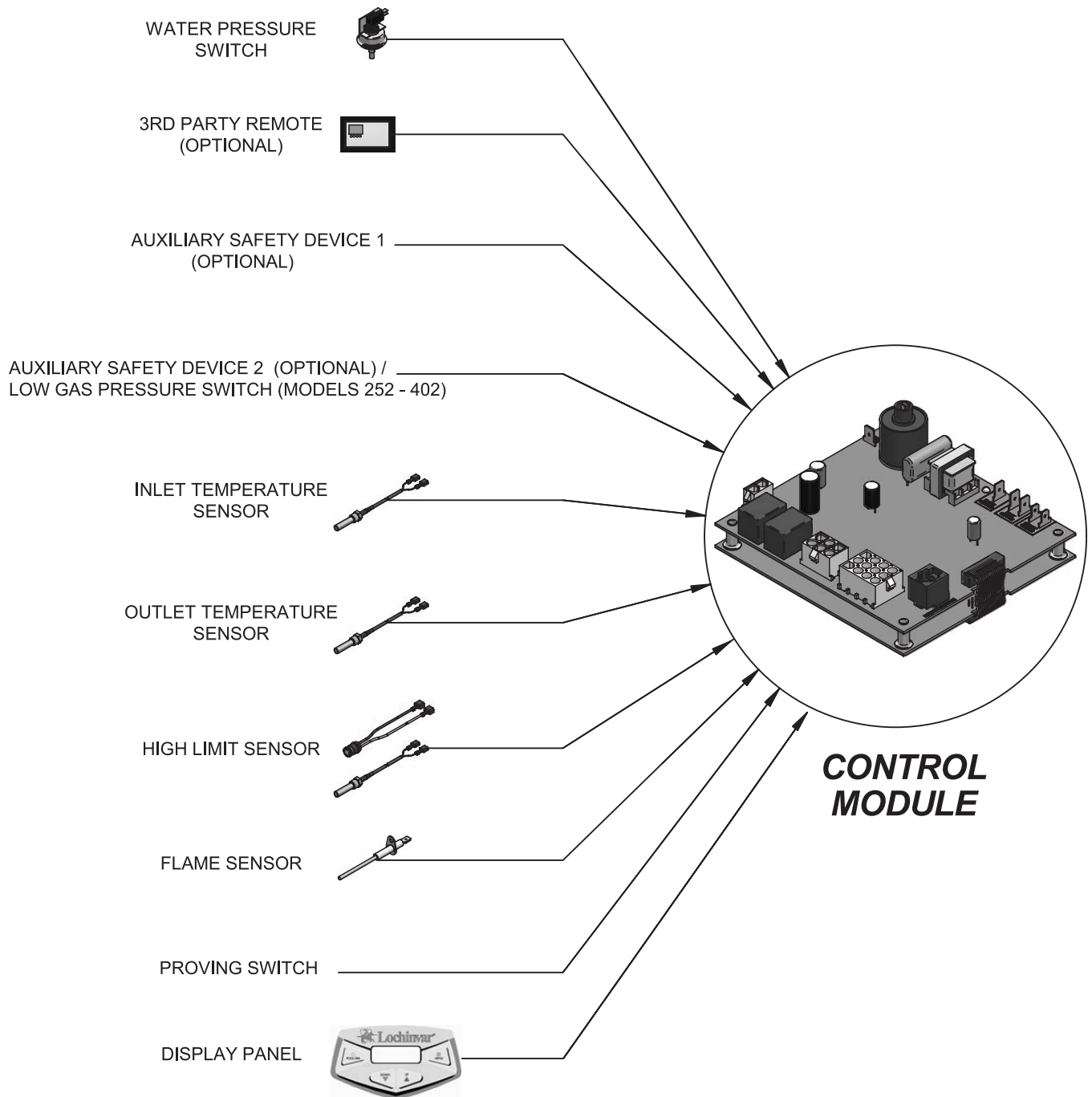

1 Service

Control outputs

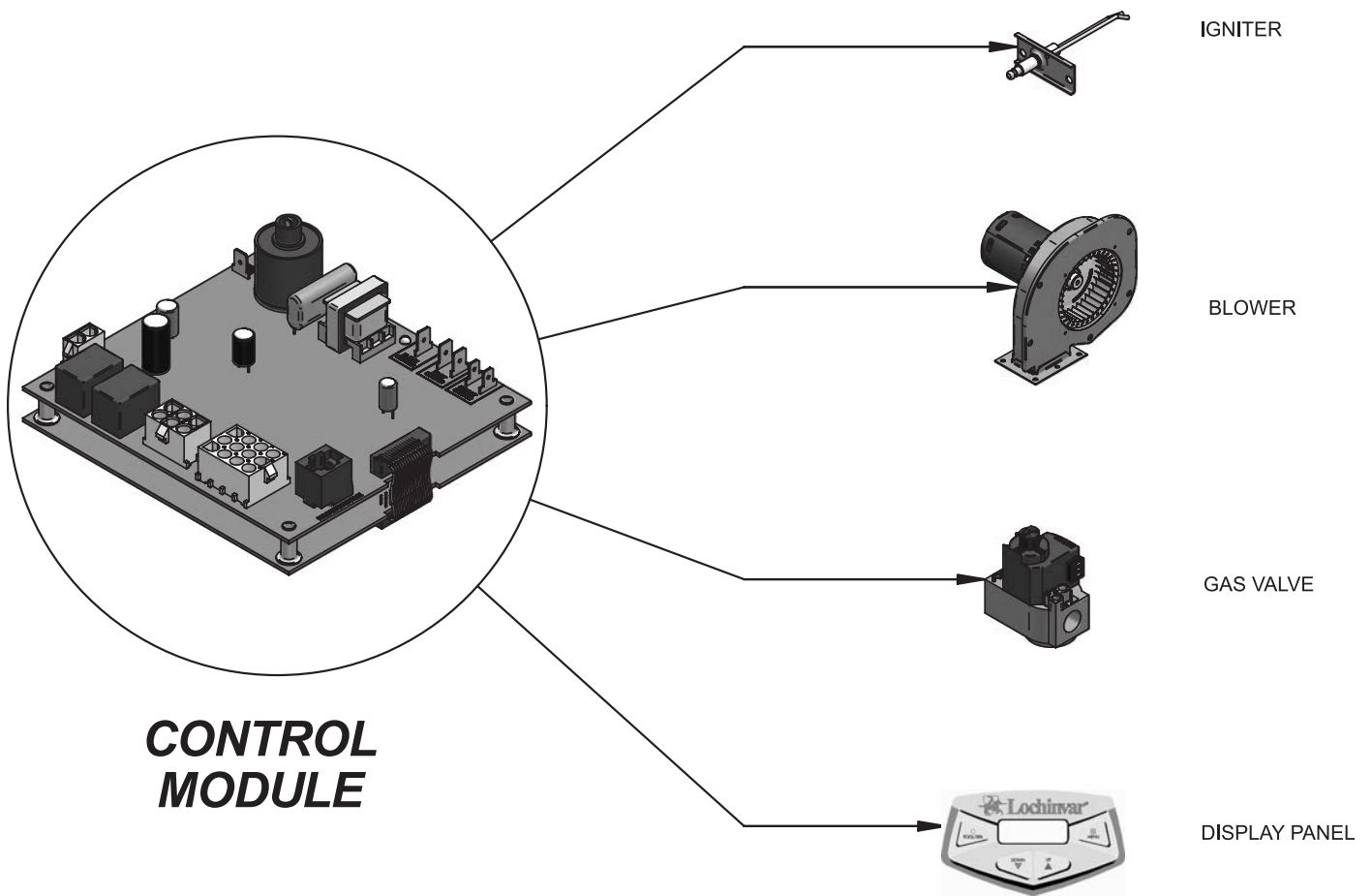

1 Service *(continued)*

General Operation

How the pool heater operates

The EnergyRite uses a copper finned tube heat exchanger and an electronic control module. The blower provides both primary and secondary air to the burners and forces the flue products out of the combustion chamber and into the vent system. The combination gas valve both regulates the manifold pressure and provides gas to the manifold, which then supplies the burners. The control and gas supply system is a fixed rate and only performs ON/OFF operation.







How the control module operates

The EnergyRite control monitors the inlet sensor which is indicative of pool/spa water temperature. The control will begin an ignition sequence when the water temperature has dropped below the set point minus the differential. It will also monitor all safety circuits and will terminate or prevent an ignition cycle if a safety circuit is open. In addition, the control will monitor the outlet temperature and will terminate a call for heat if the outlet temperature gets too high.

1 Service

Access setup menu

Table 1A Use this procedure to access the **Setup Menu** from the display panel

BUTTON		OPERATION	DISPLAY	COMMENTS
	MENU	Hold for 5 seconds -- display will change	Setup Menu	Setup Menu will be displayed for 3 seconds and will then advance to the first screen.
	MENU	Press 1 time to advance to the next screen	Pool/Spa Remote Disabled	Use the up and down arrow keys to adjust setting.
	MENU	Press 1 time to advance to the next screen	Differential 2	Use the up and down arrow keys to adjust setting.
	MENU	Press 1 time to advance to the next screen	Temp Scale °F	Use the up and down arrow keys to adjust setting.
	MENU	Press 1 time to advance to the next screen	Restore Defaults NO	Use the up and down arrow keys to adjust setting.
	MENU	Press 4 times to advance to the next screen	Set Passcode 1234	Use the up and down arrow keys to adjust setting.

The pool heater will continue to operate while the Setup Menu is being accessed. To adjust settings, press the MENU button until the desired screen is displayed. Use the UP and DOWN buttons to adjust the setting within the screen. By pressing the MENU or POOL/SPA button the new setting will be stored into memory and the next screen will be displayed.

When adjusting “set passcode” the 4 individual digits can be adjusted. The digit on the far left will be active first. Use the UP and DOWN buttons to adjust the digit. Once the MENU button is pushed, that digit is stored into memory and the next digit to the right is active. Continue on until all digits have been adjusted.

After 1 minute of inactivity, all settings are stored and the control will exit the Setup Menu. To manually exit the Setup Menu at any time, press the POOL/SPA button once.

Setup menu descriptions

Pool/spa remote

This setting allows the user to enable or disable the remote capability of switching from pool to spa. The default setting is disable.

There are three (3) options under this menu: T Stat, Switch, and Disable.

T Stat - Select this option when the heater is used in conjunction with a two wire remote system which includes its own thermostat. This option will automatically set the set point to 104° (max.) and all messages on the display will become generic (i.e. no references to pool or spa). Where there is no call for heat the pool heater will remain in Standby Mode.

Switch - Select this option when the heater is used in conjunction with a three wire remote system, also known as a three-way switch. The remote will control the pool heater if it is in Pool, Spa, or Standby Mode and will utilize the thermostat on the heater. When there is no call for Pool or Spa Mode, the pool heater will remain in Standby Mode.

When in T Stat or Switch Mode, the user can turn the control “OFF” by pressing the POOL/SPA button on the display.

Disable - This is the default setting. When this option is selected the heater will ignore all inputs on R, Ws, and Wp. The heater will not recognize any of the remotes.

For additional wiring instructions consult the third party remote manufacturer along with the *EnergyRite Installation and Operation Manual*.

Differential

This setting allows the user to choose how far below set point the water temperature must drop before the control will initiate a call for heat. The range of adjustment is from 1°F to 15°F. The default setting is 2°F.

Temperature scale

This setting allows the user the choice of showing the displayed temperature in degrees Fahrenheit or degrees Celsius. The default setting is Fahrenheit.

Restore defaults

This setting allows the user to restore the factory default settings for the Setup Menu and temperature settings.









Set passcode

This setting allows the user to set a personal passcode that would be required to lock and unlock the keypad. See *Keypad Lockout* on page 12 of this manual. The default passcode is 1234.

1 Service *(continued)*

Access service menu

Table 1B Use this procedure to access the **Service Menu** from the display panel

BUTTON		OPERATION	DISPLAY	COMMENTS
	POOL/SPA	Hold for 5 seconds -- display will change	Service Menu	Service Menu will be displayed for 3 seconds and will then advance to the first screen.
	DOWN	Press 1 time to advance to the next screen	Delta T = °F Flame Signal = Yes/No	
	DOWN	Press 1 time to advance to the next screen	Inlet = °F Outlet = °F	
	DOWN	Press 1 time to advance to the next screen	Cycles 0000	
	DOWN	Press 1 time to advance to the next screen	1 - Lockout 2 - Lockout	
	DOWN	Press 1 time to advance to the next screen	3 - Lockout 4 - Lockout	
	DOWN	Press 1 time to advance to the next screen	5 - Lockout 6 - Lockout	
	DOWN	Press 1 time to advance to the next screen	7 - Lockout 8 - Lockout	
	DOWN	Press 1 time to advance to the next screen	9 - Lockout 10 - Lockout	

Service menu descriptions

The screens may also be scrolled backwards by pressing the UP button. The pool heater will continue to operate while the Service Menu is being accessed. To exit the Service Menu press the POOL/SPA button. The control will exit the Service Menu automatically after 20 minutes of inactivity.

Delta T

This is the difference between the inlet and outlet water temperatures.

Flame signal

Yes = Flame Present

No = Flame Not Present

Inlet temperature

This is the water temperature as measured by the inlet water sensor.

Outlet temperature

This is the outlet temperature as measured by the outlet water sensor.

Cycles

The control will log the number of successful ignition attempts. After each successful ignition attempt the number will be increased by one.

Lockout screens

The control will log the 10 most current lockouts. Screens 4 - 8 will show the lockouts starting with the most current to the oldest.

1 Service

Keypad lockout

Locking the keypad

The user has the ability to lock the keypad to prevent unauthorized adjustments. To lock the keypad, the user must first select and input a passcode. See *Set Passcode* under Setup Menu Descriptions on page 10 of this manual. Once a passcode has been set, press and hold the UP and DOWN buttons simultaneously for 5 seconds. The Display Screen will show ENTER PASSCODE. The digit on the far left will be blinking. Use the UP and DOWN buttons to adjust the digit. Press the MENU button to advance to the next digit to the right. Use the UP and DOWN buttons to adjust the digit. Press the MENU button to advance to the next digit to the right. Repeat this process until all four digits have been set. Once the last digit has been set, press the MENU button.

If the passcode has been entered correctly, the display will show LOCKED for 3 seconds and will then resume normal operation. If the passcode has been entered incorrectly, the display will show INCORRECT PASSCODE for 3 seconds and will then return to the Passcode Screen for retry. If there is no button activity for 5 seconds the keypad will remain unlocked.

If the keypad has been successfully locked, when any button is pressed, the display will read LOCKED for 5 seconds and will then resume normal operation.

Unlocking the keypad

Press any button and hold for 5 seconds. The Display Screen will show ENTER PASSCODE. The digit on the far left will be blinking. Use the UP and DOWN buttons to adjust the digit. Press the MENU button to advance to the next digit to the right. Use the UP and DOWN buttons to adjust the digit. Press the MENU button to advance to the next digit to the right. Repeat this process until all four digits have been set. Once the last digit has been set, press the MENU button.

If the passcode has been entered correctly the display will show UNLOCKED for 5 seconds and will then resume normal operation.

If the passcode has been entered incorrectly the display will show INCORRECT PASSCODE for 5 seconds and will then return to the Passcode Screen for retry. If there is no button activity for 5 seconds the keypad will remain locked.

2 Maintenance

Maintenance and annual startup

Table 2A Service and Maintenance Schedules

Service technician (see the following pages for instructions)		Owner maintenance (see the EnergyRite User's Information Manual for instructions)	
ANNUAL START-UP	General:	Daily	<ul style="list-style-type: none"> • Check pool heater area
	<ul style="list-style-type: none"> • Address reported problems • Inspect interior; clean and vacuum if necessary • Check for leaks (water, gas, and flue) • Verify flue and air lines in good condition and sealed tight • Check control settings per the <i>Access Setup Menu</i> section of this manual • Check ignition and flame sense electrodes (sand off any deposits; clean and reposition) • Check wiring and connections • Perform start-up checkout and performance verification per Section 9 in the EnergyRite Installation and Operation Manual. • Flame inspection (stable, uniform) 	Monthly	<ul style="list-style-type: none"> • Check vent piping • Check air inlet piping (if applicable) • Check relief valve (if applicable)
	If combustion or performance indicate need:	Periodically	<ul style="list-style-type: none"> • Test low water cutoff (if used) • Reset button (low water cutoff)
	<ul style="list-style-type: none"> • Clean burners • Clean heat exchanger 	Every 6 months	<ul style="list-style-type: none"> • Check pool heater piping (gas and water) for leaks • Operate relief valve (if applicable)
		End of season	<ul style="list-style-type: none"> • Shut the pool heater down and winterize if location is subjected to freezing temperatures, see the <i>Winterizing</i> on page 21 of this manual

2 Maintenance

⚠ WARNING Follow the service and maintenance procedures given throughout this manual and in component literature shipped with the pool heater. Failure to perform the service and maintenance could result in damage to the pool heater or system. Failure to follow the directions in this manual and component literature could result in severe personal injury, death, or substantial property damage.

⚠ WARNING The pool heater should be inspected annually only by a qualified service technician. In addition, the maintenance and care of the pool heater designated in Table 2A, *Maintenance and Annual Startup* section and explained on the following pages must be performed to assure maximum pool heater efficiency and reliability. Failure to service and maintain the pool heater and system could result in equipment failure.

⚠ WARNING Electrical shock hazard – Turn off power to the pool heater before any service operation on the pool heater except as noted otherwise in this instruction manual. Failure to turn off electrical power could result in electrical shock, causing severe personal injury or death.

Listed in this section are items that must be checked to ensure safe reliable operations. Verify proper operation after servicing.

1. Examine the venting system at least once a year. Check more often in first year to determine inspection interval.

⚠ CAUTION Label all wires prior to disconnection when servicing controls. Wiring errors can cause improper and dangerous operation.

Outdoor Installations - Check vent cap for proper mounting, corrosion or any obstruction of the flue outlet or combustion air inlet.

Indoor Installations - Check all joints and pipe connections for tightness, corrosion or deterioration. Have the entire system, including the venting system, periodically inspected by a qualified service agency.

Address reported problems

1. Inspect any problems reported by the owner and correct before proceeding.

Inspect pool heater area

1. Verify that the pool heater area is free of any combustible materials, gasoline and other flammable vapors and liquids.
2. Verify that air intake area is free of any contaminants.

Inspect boiler interior

1. Remove the top and front access cover and inspect the interior of the pool heater.
2. Vacuum any sediment from inside the pool heater and components. Remove any obstructions.

Check all piping for leaks

1. Inspect all water and gas piping and verify to be leak free.
2. Look for signs of leaking lines and correct any problems found.
3. Check gas line using the procedure found in Section 6 - Gas Connections of the EnergyRite Installation and Operation Manual.

Flue vent system and air piping

1. Visually inspect the entire flue gas venting system and air piping for blockage, deterioration or leakage. Repair any joints that show signs of leakage. Verify that air inlet pipe is connected and properly sealed.
2. Verify that the pool heater vent discharge and air intake are clean and free of obstructions.
3. Flue Gas Passageways Cleaning Procedures: Any sign of soot around the outer jacket, at the burners or in the areas between the fins on the copper heat exchanger indicates a need for cleaning. The following cleaning procedure must only be performed by a qualified serviceman or installer. Proper service is required to maintain safe operation. Properly installed and adjusted pool heaters seldom need flue cleaning.

All gaskets on disassembled components **MUST** be replaced with new gaskets on reassembly. Gasket kits are available from your distributor.

2 Maintenance *(continued)*

Inspect ignition and flame sense electrodes

1. Remove the ignition and flame sense electrodes from the combustion chamber door.
2. Remove any deposits accumulated on the ignition/flame sense electrode using sandpaper. If the electrodes cannot be cleaned satisfactorily, replace with new ones.
3. Replace ignition/flame sense electrode, making sure gasket is in good condition and correctly positioned.

Check ignition ground wiring

1. Inspect pool heater ground wire from the combustion chamber door to the ground terminal on the control module.
2. Verify all wiring is in good condition and securely attached.
3. Check ground continuity of wiring using continuity meter.
4. Replace ground wires if ground continuity is not satisfactory.

Check all pool heater wiring

1. Inspect all pool heater wiring, making sure wires are in good condition and securely attached.

Check burner flame

Visually check main burner flames at each start up after long shutdown periods or at least every six months. A burner viewport is located on the right side of the pool heater, below the water connections on the front header. Remove cap to view flame.

⚠ WARNING The area around the burner viewport is hot and direct contact could result in burns.

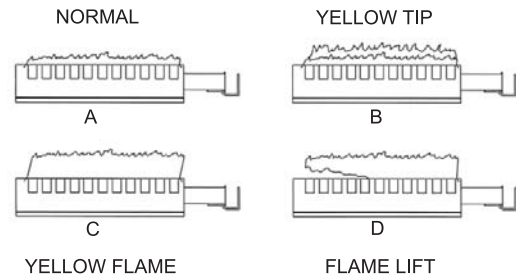

Figure 2-1_Flame Pattern Illustration

- a) Normal Flame: A normal flame is blue, with slight yellow tips, with a well defined inner cone and no flame lifting.
- b) Yellow Tip: Yellow tip can be caused by blockage or partial obstruction of air flow to the burner(s).
- c) Yellow Flames: Yellow flames can be caused by blockage of primary air flow to the burner(s) or excessive gas input. This condition **MUST** be corrected immediately.
- d) Lifting Flames: Lifting flames can be caused by over firing the burner(s), excessive primary air or high draft.

Burner removal and cleaning

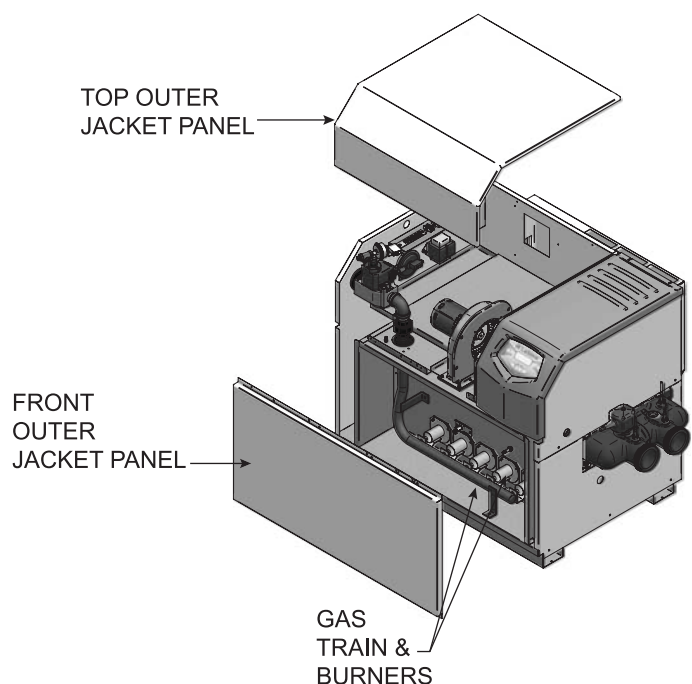

Figure 2-2_Gas Train and Burners

2 Maintenance

1. Burner removal and cleaning procedure:
 - a) Turn off main power to the pool heater.
 - b) Turn off main manual gas shutoff to the pool heater.
 - c) Remove the front and top outer jacket panels.
 - d) Disconnect the gas supply from the gas valve manifold assembly with a field supplied union before the gas valve. Disconnect the union between the gas valve and the manifold.

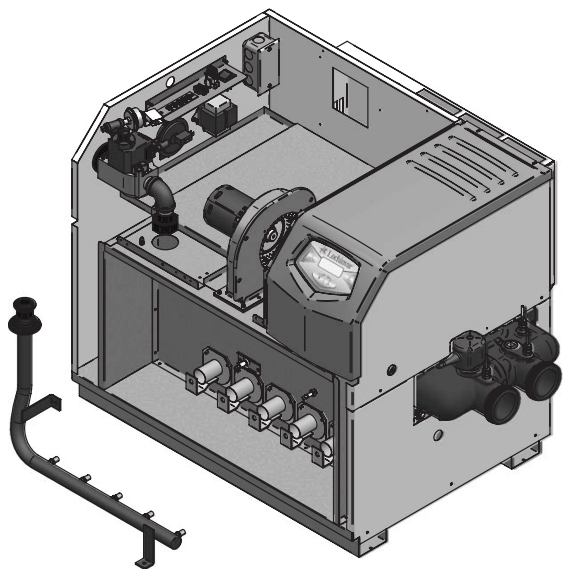

Figure 2-3_Gas Train Detached for Burner Removal

- e) Remove mounting screws from the manifold mounting brackets. Remove the manifold/orifice assembly from the burners (FIG. 2-3).
- f) Remove the mounting screws from each burner and slide the burner out toward the front of the pool heater. Use caution to prevent damage to burners, burner gaskets, refractory, spark igniter, flame sense, or wiring.
- g) Remove soot from burners with a stiff bristle brush. Dirt may be removed from the burner ports by rinsing the burner thoroughly with water. Drain and dry burners before re-installing. Damaged burners must be replaced.

A pool heater installed in a dust or dirt contaminated atmosphere will require cleaning of the burners on a 3 to 6 month schedule or more often, based on severity of contamination. Contaminants can be drawn in with the combustion air. Non-combustible particulate matter such as dust, dirt, concrete dust, or drywall dust can block burner ports and cause non-warrantable failure. Use extreme care when operating a pool heater during new construction. The burners will probably require a thorough cleaning before the pool heater is placed in service.

⚠ WARNING

The combustion chamber lining in this appliance contains ceramic fiber materials. Ceramic fibers can transform into cristobalite (crystalline silica) when exposed to temperatures above 2192°F (1200°C) dependent upon the length of exposure time.*

The International Agency for Research on Cancer (I.A.R.C.) has concluded, "Crystalline silica inhaled in the form of quartz or cristobalite from occupational sources is carcinogenic to humans."**

Testing has confirmed that the ceramic fibers in this application do not reach 2192°F (1200°C).

*Reference Dyson, D., Butler, M., Hughes, R., Fisher, R., and Hicks, G. The Devitrification of Alumino-silicate Ceramic Fiber Materials - The Kinetics of the Formation of Different Crystalline Phases, Ann. Occup. Hyg. Vol. 41, No. 55, 1997.

**Reference I.A.R.C. Monograph 68, June 1997.

NOTICE

The ceramic fiber material used in this appliance is an irritant; when handling or replacing the ceramic materials it is advisable that the installer follow these safety guides.

Removal of combustion chamber lining or base panels:

- Avoid breathing dust and contact with skin and eyes.
- Use NIOSH certified dust respirator (N95) (<http://www.cdc.gov/niosh/homepage.html>).
- Lightly mist with water (only those areas being handled) the combustion chamber lining or base insulation to prevent airborne fibers.
- Remove combustion chamber lining or base insulation from the pool heater and place it in a plastic bag for disposal.
- Wash potentially contaminated clothes separately from other clothing. Rinse clothes thoroughly.
- NIOSH stated First Aid:
 - Eye:** Irrigate immediately.
 - Breathing:** Fresh air.

2 Maintenance *(continued)*

Heat exchanger cleaning

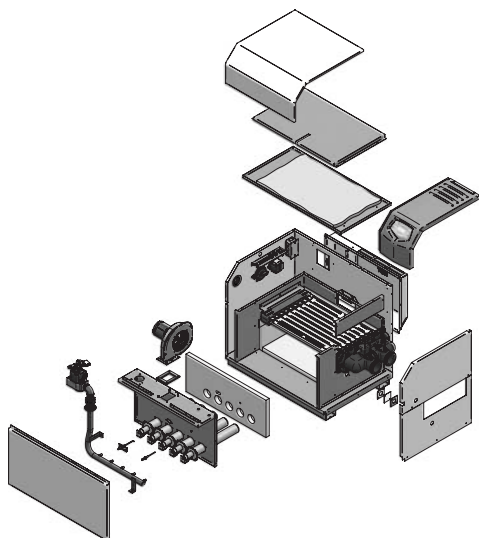

Figure 2-4 *Exploded View of the Heater*

- h) While burners are removed, check the heat exchanger surface for sooting. If soot is present, heat exchanger must be cleaned and problem corrected. Proceed as follows:
 - i) Disconnect the connector from the combustion fan.
 - j) Disconnect the spark ignition wire from the back of the control module.
 - k) Disconnect the flame rod wire from the back of the control module.
 - l) Remove the screws around the combustion chamber door. Remove the combustion chamber door from the unit.
 - m) Remove soot from the heat exchanger with a stiff bristle brush. Use a vacuum to remove loose soot from surfaces and inner chamber.

NOTICE Do not wet the pool heater's refractory.

- n) Ensure that all burner ports are cleaned to remove any soot. See the *Burner Cleaning Procedure* section on page 16 of this manual.
- o) Carefully reinstall the "V" baffles if removed from the pool heater.
- p) Reinstallation is the reverse of the installation procedure. Use new gasket material to ensure a proper air seal.
- q) Reassemble all gas piping. Test for gas leaks.
- r) Reassemble outer jacket panels.
- s) Cycle the pool heater and check for proper operation.

2. Combustion Air Fan: The combustion air fan should be checked every 6 months or each season of operation. Clean fan as required when installed in a dust or dirt contaminated location.
3. Water Circulating Pump: Ensure that the filter system pump is providing adequate flow to the pool heater. Backwash and clean filter as required to maintain proper flow.
4. Keep the pool heater area clear and free from combustible materials, gasoline, and other flammable vapors and liquids.
5. Check frequently to be sure the flow of combustion and ventilation air to the pool heater is not obstructed.
6. This pool heater uses a transformer to supply a low voltage control circuit. The voltage on the secondary side should be 24 to 28 VAC when measured with a voltmeter.
7. Direct Spark Igniter Replacement: The direct spark igniter can be replaced with an OEM igniter available from your dealer.

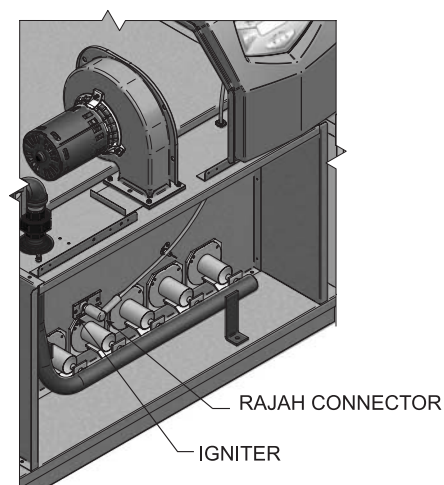

Figure 2-5 *Igniter Replacement*

- a) Turn off main power to the pool heater.
- b) Turn off main manual gas shutoff to the pool heater.
- c) Remove the front outer jacket panels to access the front chamber.
- d) Disconnect the rajah connector from the igniter (FIG. 2-5).
- e) Remove the igniter retaining screws and slide the igniter out of the combustion chamber.
- f) Install the new igniter into the combustion chamber.
- g) Reattach the rajah connector to the new igniter.
- h) Reassemble in reverse order.

2 Maintenance

Combustion Air Shutter Adjustment

This pool heater uses a fan assisted combustion process. The fan air shutter is factory preset and should not need adjusting in most cases. If adjustment is required, the fan air shutter may be manually adjusted to a dimension specified for each model (see Table 2B).

Follow the steps below to adjust the fan air shutter if the pool heater does not function properly or a continuous low air condition is observed:

1. Check for proper installation and draft in the venting system. Correct as required.
2. Remove the upper left access door (FIG. 2-6).
3. Turn the power switch to the "OFF" position.
4. Turn the gas valve switch to the "OFF" position.
5. Use a ruler to measure the distance from the base of the fan to the end of the air shutter (FIG. 2-7). Compare this distance to the specified "A" dimension for the pool heater in Table 2B.
6. Turn all gas valve knobs and the manual gas cock to the "OFF" position.
7. Locate the air pressure switch located on the left side panel. Trace the hose from the air pressure switch to the chamber pressure barb located in the top of the upper chamber. Remove the hose from the chamber pressure barb and connect the hose from the manometer or magnahelic to this barb to measure the air pressure in the front chamber.
8. Turn the power switch to the "ON" position.
9. Set the thermostat to call for heat. The fan will start.
10. While the combustion air fan is running for the prepurge cycle and the pressure in the front chamber stabilizes, record the pressure in the front chamber. This pressure will be used to calculate the net manifold pressure.
11. Turn the power switch to the "OFF" position.
12. Remove the manometer or magnahelic hose from the front chamber barb and reinstall the hose from the air pressure switch to the barb.
13. If the pressure switch still exhibits failures, check the differential air pressure measurement.

Model	"A" Dimension Opening	Chamber Pressure
ER152	1 1/4"	1.4"
ER202	1 1/4"	1.4"
ER252	1 3/8"	1.4"
ER302	1 9/16"	1.4"
ER402	1 3/4"	1.4"

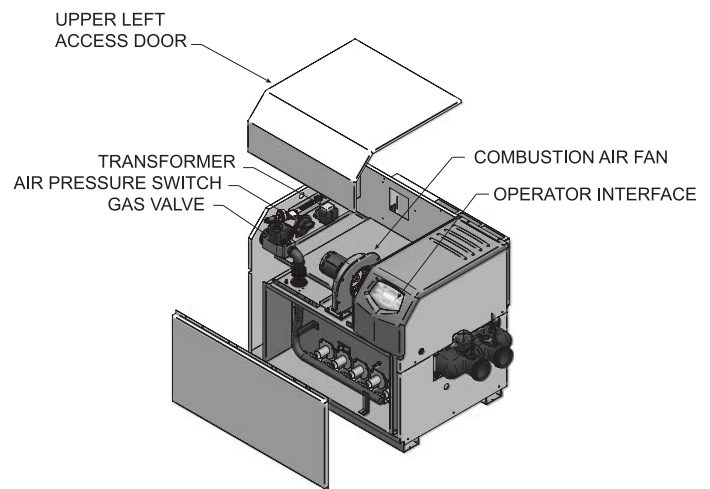

Figure 2-6_Combustion Air Fan Location

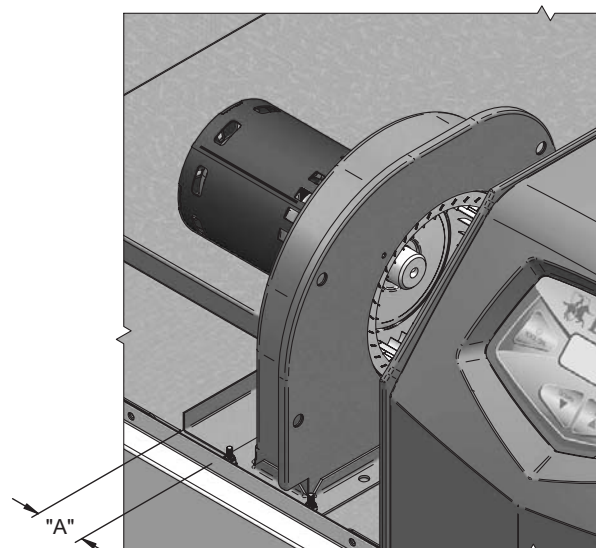

Figure 2-7_Combustion Air Fan with Air Shutter "A" Dimension

2 Maintenance *(continued)*

Differential air pressure measurement

The differential air pressure measurement can be checked with a slack tube manometer (FIG. 2-8). Disconnect the two tubes from the air pressure switch and connect one to each side of a manometer. Turn on the pool heater and allow the combustion air fan to operate. The observed pressure reading on the manometer should correspond to the range shown in Table 2C - Differential Air Chart if the air shutter is properly adjusted. The differential pressure varies based on air density at elevation.

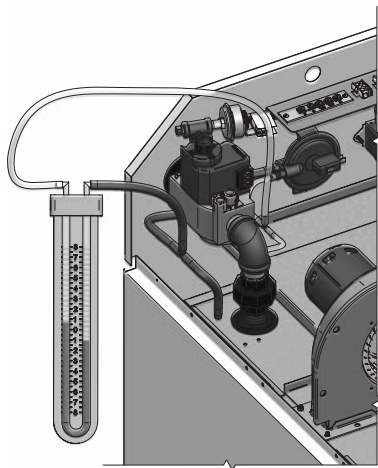

Figure 2-8_Air Shutter Pressure Measurement

TABLE - 2C DIFFERENTIAL AIR CHART	
Differential Air	Elevation
1.65" - 1.80" w.c.	0 - 4,000'
1.40" - 1.60" w.c.	4,000' - 8,000'
1.20" - 1.40" w.c.	8,000' - 12,000'

Gas train and controls

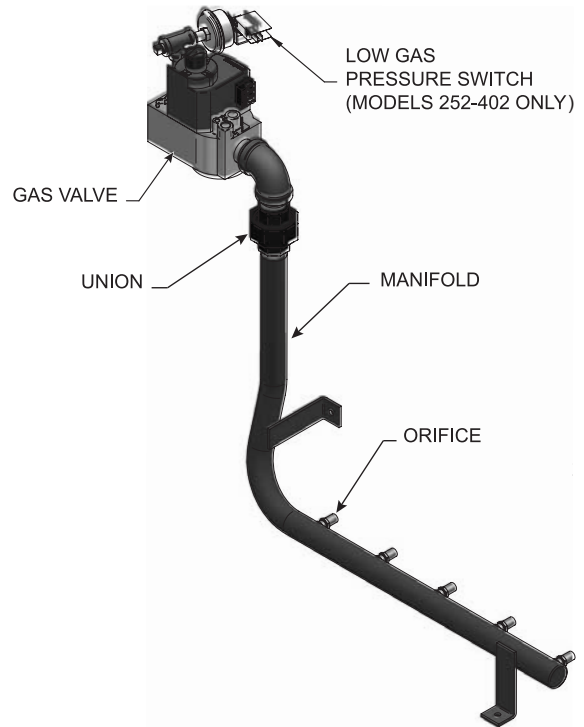

Figure 2-9_Gas Train Drawing

NOTICE

The gas train and controls assembly provided on this pool heater have been tested under the applicable American National Standard to meet minimum safety and performance criteria such as safe lighting, combustion, and safety shutdown operation.

2 Maintenance

Facts about water chemistry

Factors which affect pool and spa water and, more importantly, the efficiency of your new pool/spa heater are:

1. Proper Filtration
2. Proper Circulation
3. Disinfection and Oxidation
4. pH Control and Total Alkalinity
5. Algae Control

The water chemistry of your pool or spa changes daily due to natural evaporation of the water and the addition of chemicals. Chemicals are used to sanitize and control algae growth in the pool. Their addition must be carefully monitored. If there is an imbalance in the pool water chemistry, the minerals in the pool water will precipitate out and collect in the pool, filter system and the pool heater. The accumulation of minerals or scale in the pool heater due to a chemical imbalance will cause a non-warrantable failure of the heat exchanger and its components.

pH is the most important factor in maintaining proper balance in your pool/spa water. pH is the measurement of the acidity or alkalinity of water. The chart in FIG. 2-10 shows the ideal pH range and what can happen when the pH increases or decreases from the ideal of 7.2 to 7.8.

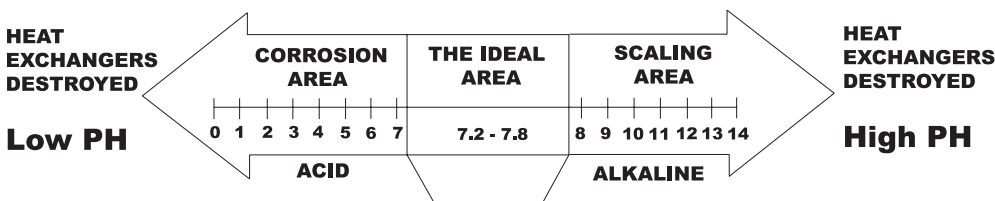

Figure 2-10_pH Scale

If the pH becomes too high, it lowers the ability of chlorine to destroy bacteria and algae, water can become cloudy, filter elements may become blocked, and scale formation will occur in the pool and heat exchanger. If the pH becomes too low the water becomes acid. You can have eye burn and skin irritation, etching of the plaster, corrosion of metal fixtures, and the resulting stains on the plaster, degradation of sand and gravel filters, and corrosion of the copper tubes in the heat exchanger. **Damage to the pool heater due to improper pH is non-warrantable.**

We recommend using a four-way test kit to monitor the following levels (see Table 2D) to ensure proper operation of your pool heater:

TABLE - 2D RECOMMENDED POOL CHEMISTRY LEVELS	
Test	Recommended Level
Correct pH	7.2 - 7.8
Chlorine Residual	1.0 - 5.0 ppm
Total Alkalinity	80 - 120 ppm
Calcium Hardness	175 - 350 ppm

Chlorine residual is the chlorine remaining in the pool water after it is consumed in the process of destroying bacteria, algae, and other oxidizable materials.

Total alkalinity is the measurement of the total amount of alkaline chemicals in the water. Alkalinity controls pH. Sodium bicarbonate is used to raise total alkalinity.

Calcium hardness can be raised by the addition of calcium chloride, and lowered by the addition of Tri-sodium Phosphate or its equivalent.

The corrosive level of pool water can also be measured by the Langlier Saturation Index. This index is calculated by a formula which uses operating temperatures, total alkalinity, pH, calcium hardness and total dissolved solids. The optimum Saturation Index value is zero. A negative value indicates a corrosive condition. Your pool/spa dealer can provide additional data and equipment to make this measurement if a problem exists.

2 Maintenance *(continued)*

Heat exchanger inspection

Tubes

This pool heater is especially designed to operate without accumulation of scale in the heat exchanger, even in very hard water. Periodic inspections of the tubes should be made to be sure that no scale is accumulating. Water piping should be disconnected at the flanges. The front header can be removed to inspect the tubes. A scale deposit of paper thickness is normal. Heavier deposits should be cleaned out.

If scale is found in the tubes, **THE CAUSE SHOULD BE FOUND AND CORRECTED**. Removal and cleaning of the heat exchanger must be performed by a qualified serviceman or installer.

The probable cause is improper water chemistry. Check the following possible causes:

1. High pH.
2. Improper adjustment of an external bypass.
3. Inadequate pump flow.

Always be sure that the filter pump is in good operating condition and runs continuously when the pool heater is in operation.

Prevention of freezing

Heat exchangers and headers damaged by freezing are not covered by warranty. If equipment is subject to freezing temperatures, the following precautions must be observed.

Winterizing

Although this pool heater is CSA design certified for outdoor installations, such installations are not recommended in areas where the pool heater will be operated in the winter months and the danger of freezing exists. Proper freeze protection must be provided for outdoor installations, pool heaters installed in unheated equipment rooms or where temperatures may drop to the freezing point or lower. If freeze protection is not provided for the system, a low ambient temperature alarm is recommended for the equipment room. Damage to the pool heater by freezing is non-warrantable.

1. Pump Operation - **MOST IMPORTANT** - This pool heater is designed for continuous operation of the filter system pump when the burners are firing. If the system pump does not run continuously an additional pump must be installed to provide constant circulation through the pool heater. The constant flow of warm pool water can help prevent freezing.
2. Location - Indoor pool heaters must be located in a room having a temperature safely above freezing [32°F(0°C)].

3. Caution - An equipment room operating under a negative pressure may experience a downdraft in the flue of a pool heater which is not firing. The cold outside air pulled down the flue may freeze a heat exchanger. This condition must be corrected to provide adequate freeze protection.
4. Outdoor Pool Heater Installation - Use extreme caution to prevent freezing. A snow screen should be installed to prevent snow and ice accumulation around the pool heater or its venting system.
5. Shutdown and Draining - If for any reason the pool heater is to be shut off when temperatures may be below 35°F (2°C), you must winterize the pool heater:
 - a) Shut off gas supply.
 - b) Shut off water supply.
 - c) Shut off electrical supply.
 - d) Locate the (1 - Non-ASME, 3 - ASME) drain(s) on the bottom of the front header (FIG.'s 2-11 and 2-12).
 - e) Open the drain(s) and allow the heat exchanger to drain completely. Leave the drain(s) open until Spring. Drain the pump and related piping.

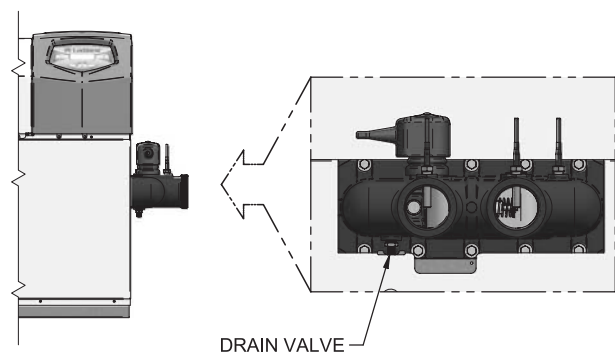

Figure 2-11_Non-ASME Drain Locations

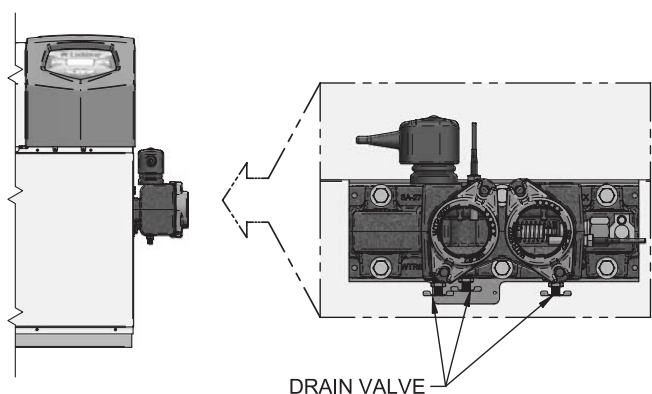

Figure 2-12_ASME Drain Locations

3 Troubleshooting

⚠ WARNING

Label all wires prior to disconnection when servicing controls. Wiring errors can cause improper and dangerous operation. Always disconnect power to the pool heater before servicing. Failure to comply could result in severe personal injury, death, or substantial property damage.

⚠ WARNING

Never jumper (bypass) any device except for momentary testing as outlined in the Troubleshooting chart. Severe personal injury, death, or substantial property damage can result.

Before troubleshooting:

1. Have the following items:
 - a. Voltmeter that can check 120 VAC, 240 VAC, 24 VAC, and 12 VDC.
 - b. Continuity checker.
 - c. Contact thermometer.
2. Check for 240 VAC (120 VAC optional) to pool heater.
3. Make sure all external limit controls are installed and operating.

Check the following:

1. Wire connectors to control module are securely plugged in at the module and originating control.
2. Gas pressures:
 - Maximum: 14 inches w.c. (natural), 14 inches w.c. (LP) with no flow (lockup) or with pool heater on.
 - Minimum: 4.0 inches w.c. (natural) on the ER152 - ER202 models, 4.5 inches w.c. (natural) on the ER252 - ER302 models, and 5.0 inches w.c. (natural) on the ER402 model.

On the ER152 - ER402 models minimum 8.0 inches w.c. (LP) with gas flowing (verify during pool heater startup).

Table 3A Troubleshooting Chart - No Display

FAULT	CAUSE	CORRECTIVE ACTION
No Display	- No 120/240 VAC supplied to the pool heater.	<ul style="list-style-type: none"> • Check external line switch, fuse, or breaker. • Check position of ON/OFF switch. Turn switch to the ON position. • Check 120 or 240 VAC through the ON/OFF switch.
	- No voltage through the switch.	<ul style="list-style-type: none"> • Replace switch.
	- Bad main control board.	<ul style="list-style-type: none"> • Replace the main control board.
No Burner Operation	- Main control board temperature set point satisfied.	<ul style="list-style-type: none"> • Review temperature setting.
	- Remote thermostat satisfied.	<ul style="list-style-type: none"> • Review remote thermostat setting.
	- Pool heater locked out on fault.	<ul style="list-style-type: none"> • Consult display for specific fault. Refer to fault descriptions on pages 25 - 27 of this manual for corrective actions.

3 Troubleshooting *(continued)*

Checking temperature sensors

The pool heater temperature sensors (inlet and outlet water) are both resistance type devices. The following table shows the correct values for the sensors at various temperatures. Use an ohmmeter to read the resistance of the sensor at a known temperature. If the resistance of the sensor does not closely match, replace the sensor.

Table 3B *Inlet/Outlet System Sensor Resistance vs. Temperature*

Temperature	Resistance
50	18,780
68	12,263
86	8,194
104	5,592
122	3,893
140	2,760

3 Troubleshooting

Table 3C Troubleshooting Chart - Noisy System

FAULT	CAUSE	CORRECTIVE ACTION
Noisy Operation	- Supply gas problem. Natural gas pressures should be between 4.0 inches w.c. and 14 inches w.c. LP gas pressures should be between 8.0 inches w.c. and 14 inches w.c.	<ul style="list-style-type: none"> Refer to Section 6 - Gas Connections of the EnergyRite Installation and Operation Manual for detailed information concerning the gas supply.
	- Dirty / damaged burners.	<ul style="list-style-type: none"> Refer to page 16 in this manual for the burner removal and inspection procedure. Clean or replace the burner as necessary.
	- Low water flow through the heat exchanger.	<ul style="list-style-type: none"> Refer to Section 7 - Water Connections of the EnergyRite Installation and Operation Manual for minimum flow rates. Verify the pool heater pump is running on a call for heat.
	- Air in the piping system.	<ul style="list-style-type: none"> Properly purge all air from the piping system.
Relief Valve Opening	- System pressure exceeds relief valve setting.	<ul style="list-style-type: none"> Lower the system pressure below the 50 PSI rating of the supplied relief valve or replace the standard relief valve with a higher rated valve up to the maximum pressure of the heat exchanger.

3 Troubleshooting *(continued)*

Table 3D Troubleshooting Chart - Fault Messages Displayed on Pool Heater Interface

FAULT	DESCRIPTION	CORRECTIVE ACTION
<p>AUX Device 1 Open</p>	<p>The field supplied safety wired into AUX Device 1 has opened. This will most commonly be a flow switch or low water cutoff.</p>	<ul style="list-style-type: none"> • Check pool heater pump operation on a call for heat. • Check for closed valves or obstructions in the pool heater piping. • Verify system is full of water and all air has been purged from the system. • Check for loose or misplaced jumpers if flow switch or LWCO is not installed. • If other safety device, ensure device is working properly and conditions are accurate.
<p>Flame Sequence (will require a manual reset once the condition has been corrected. Press the RESET button on the display to reset.)</p>	<p>The flame detector circuit is seeing a flame signal while no flame is present.</p>	<ul style="list-style-type: none"> • Check supply voltage for proper polarity. • Check external wiring for voltage feedback. • Check the flame rod and make sure it is clean. • Check the internal wiring for bad connections. • Replace main control board.
<p>Ignition Failure (will require a manual reset once the condition has been corrected. Press the RESET button on the display to reset.)</p>	<p>The pool heater has failed to prove main burner ignition after four (4) attempts.</p>	<ul style="list-style-type: none"> • Check for proper electrical grounding of the pool heater. • Check incoming supply gas pressure. Natural gas pressures should be between 4.0 - 14 inches w.c. and LP gas pressures should be between 8.0 - 14 inches w.c. Refer to Section 6 - Gas Connections of the EnergyRite Installation and Operation Manual for detailed information concerning the gas supply. • Verify that the outdoor vent cap or vent/air intake pipes are installed correctly and that there are no obstructions. • Check for 24 VAC to the gas valve. • If 24 VAC is present at the main control board, check the wiring between the main control board and the gas valve. Replace the wiring if necessary. • If 24 VAC is present, check the outlet of the valve to ensure the valve is flowing gas. With a manometer connected to the outlet tap of the gas valve there should be very little pressure during pre-purge. Once the ignition begins, the pressure should jump to around 3 inches. If this sudden change does not happen then the valve is not opening. • Inspect the burner. Reference page 16 of this manual for removal and cleaning procedures. Replace if necessary. • Replace the main control board.

3 Troubleshooting

Table 3D (continued from previous page) *Troubleshooting Chart - Fault Messages Displayed on Pool Heater Interface*

FAULT	DESCRIPTION	CORRECTIVE ACTION
High Limit Open	The outlet water temperature has exceeded the fixed setting of the automatic reset high limit.	<ul style="list-style-type: none"> • Verify that the system is full of water and that all air has been properly purged from the system. • Verify that the pool heater is piped properly into the heating system. Refer to Section 7 - Water Connections of the EnergyRite Installation and Operation Manual for the proper piping methods for the pool heater. • Replace the main control board if necessary. • Check resistance of water sensors and compare to Table 3B on page 23 of this manual. Replace sensor if necessary. • Replace high limit.
Sensor Shorted	Either the inlet water or outlet water temperature sensor has been shorted.	<ul style="list-style-type: none"> • Check the sensors and their associated wiring. Repair or replace the sensor or wiring if damaged. • Measure the resistance of the sensors and compare the resistance to Table 3B on page 23 of this manual. • Replace the sensor if necessary.
AUX Device 2 Open	<p>Models 152 - 202: The field supplied safety wired into AUX Device 2 has opened.</p> <p>Models 252 - 402: The low gas pressure switch has not closed.</p>	<ul style="list-style-type: none"> • Models 152 - 202: Ensure other safety devices are working properly and conditions are correct. • Models 252 - 402: Ensure there is proper gas supply pressure to the pool heater.
Proving Switch	External proving switch has not closed.	<ul style="list-style-type: none"> • Ensure the external proving switch is connected and operating properly.
Air Switch Open	The combustion air chamber is not reaching the proper pressure.	<ul style="list-style-type: none"> • Ensure there is no blockage of the flue or air inlet. • Ensure the front combustion air chamber is sealed properly. • Ensure proper voltage is being delivered to the pool heater. • Ensure the pressure switch wiring and hoses are all in good condition and sealed properly.
Air Switch Short	The control sensed an air pressure switch closure prior to powering the blower.	<ul style="list-style-type: none"> • Ensure the switch is wired properly. • Replace the switch.

3 Troubleshooting *(continued)*

Table 3D (continued from previous page) *Troubleshooting Chart - Fault Messages Displayed on Pool Heater Interface*

FAULT	DESCRIPTION	CORRECTIVE ACTION
Pool Standby / Low Water Flow	The pool heater has a call for heat, but there is insufficient water flow.	<ul style="list-style-type: none"> • Verify that the system is full of water and that all air has been properly purged from the system. • Verify that the pool heater is piped properly into the heating system. Reference Section 7 - Water Connections in the EnergyRite Installation and Operation Manual for the proper piping methods for the pool heater. • Replace the switch.
Outlet Sensor Open	The control does not sense the presence of an outlet sensor.	<ul style="list-style-type: none"> • Ensure proper wiring of the outlet sensor. • Replace the sensor. • Replace the main control board.
Inlet Sensor Open	The control does not sense the presence of an inlet sensor.	<ul style="list-style-type: none"> • Ensure proper wiring of the inlet sensor. • Replace the sensor. • Replace the main control board.
Outlet Temp Exceeded	The outlet temperature has exceeded the maximum allowable outlet temperature.	<ul style="list-style-type: none"> • Verify that the system is full of water and that all air has been properly purged from the system. • Verify that the pool heater is piped properly into the heating system. Reference Section 7 - Water Connections in the EnergyRite Installation and Operation Manual for the proper piping methods for the pool heater. • Measure the resistance of the sensors and compare the resistance to Table 3B on page 23 of this manual. • Replace the sensor if necessary.
Lockout / Low Water Flow	The pool heater sensed low water pressure while the pool heater was running.	<ul style="list-style-type: none"> • Verify that the system is full of water and that all air has been properly purged from the system. • Verify that the pool heater is piped properly into the heating system. Reference Section 7 - Water Connections in the EnergyRite Installation and Operation Manual for the proper piping methods for the pool heater.
Button Malfunction	One of the buttons has malfunctioned.	<ul style="list-style-type: none"> • Replace the board.

3 Troubleshooting

Gas manifold pressure adjustment procedure

NOTICE

The gas valve is referenced to the fan pressurized chamber by a hose connected from the vent of the gas valve regulator to the chamber pressure tap located on the left side of the jacket. Reference the figures in this section for component location and connection points for pressure measurement. The referenced chamber pressure must be subtracted from the manifold pressure to obtain actual net manifold pressure for normal operation. A manometer or magnahelic gauge legible in 0.1" increments up to 10" water column is required to check and adjust the manifold pressure. The regulator cover screw on the gas valve must be in place and tight for the appliance to operate properly.

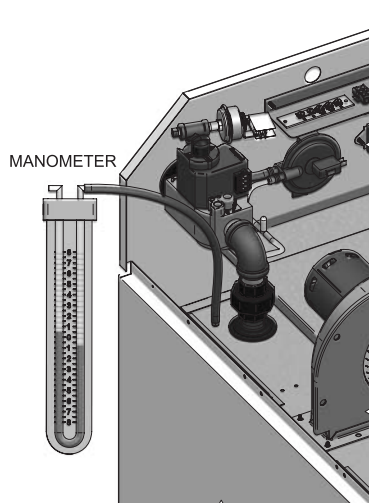

Figure 3-1_Front Chamber Pressure Measurement

1. Turn the power switch to the "OFF" position.
2. Remove the top front jacket panel.
3. Turn all gas valve knobs and the manual gas cock to the "OFF" position.
4. Locate the air pressure switch located on the left side panel. Trace the hose from the air pressure switch to the chamber pressure barb located in the top of the upper chamber. Remove the hose from the chamber pressure barb and connect the hose from the manometer or magnahelic to this barb to measure the air pressure in the front chamber.

5. Turn the power switch to the "ON" position.
6. Set the thermostat to call for heat. The fan will start.
7. While the combustion air fan is running for the prepurge cycle and the pressure in the front chamber stabilizes, record the pressure in the front chamber. This pressure will be used to calculate the net manifold pressure.
8. Turn the power switch to the "OFF" position.
9. Remove the manometer or magnahelic hose from the front chamber barb and reinstall the hose from the air pressure switch to the barb.

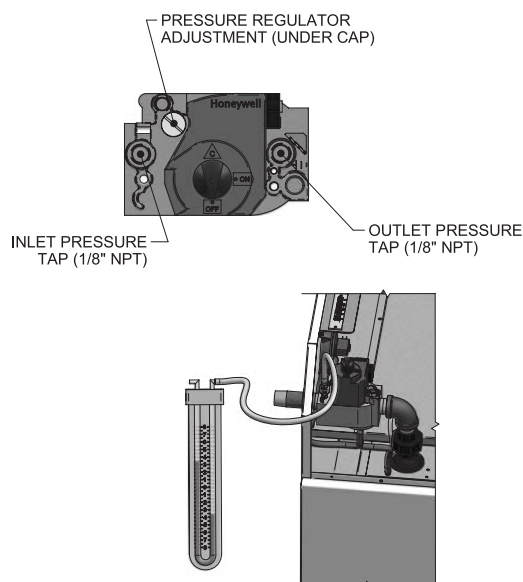

Figure 3-2_Manifold Gas Pressure Measurement

10. Remove the 1/8" hex plug, located on the "outlet" side of the gas valve and install a fitting suitable to connect to a manometer or magnahelic gauge (see FIG. 3-2). Minimum range of scale should be up to 5" w.c. for natural gas and 10" w.c. for propane gas.
11. A reference pressure hose is factory installed from the barbed connection on the gas valve regulator to the fan pressurized front chamber. All manifold pressure measurements made with the reference hose in place will be the sum of the net manifold pressure and the air pressure in the front chamber.
12. Turn the power switch to the "ON" position.
13. Turn all gas valve knobs to the "ON" position.
14. Set the thermostat to call for heat.
15. Before the valve opens, the manometer or magnahelic gauge will read a positive air pressure of 1.4" w.c. to 1.8" w.c. in the jacket as supplied by the combustion air fan in the pressure cycle. There is no gas flow at this point. This air pressure reading is normal.

3 Troubleshooting *(continued)*

16. The gas valve will open at the end of the trial for ignition stage and remain open as the burners fire. Observe the gas manifold pressure when valves open. If insufficient gas pressure is supplied to the burners, the burners will not fire. Record the gas pressure indicated on the manometer or magnahelic. Subtract the air pressure in the front chamber (as recorded in Step 7) from the gross manifold pressure observed at the end of trial for ignition and when the burners are firing. The gross manifold pressure will typically be within the range of 3.0" w.c. to 3.5" w.c. for Natural Gas and 5.8" w.c. to 6.3" w.c. for LP Gas at full fire. The difference in the gross manifold pressure and the front chamber pressure is the net manifold pressure setting of the gas valve's regulator. Compare the net setting to the setting specified for the type of gas used. Adjust regulator as required. Set the thermostat to a setting lower than the appliance's water temperature to turn the burners off. Allow appliance to run through the post purge sequence. Turn the power switch to the "OFF" position.
19. Replace the cover screw on the regulator and turn the power switch to the "ON" position. Set the thermostat to call for heat. Observe gas regulator pressure again at the burner "ON" stages. Repeat this sequence until the proper regulator setting has been obtained.

NOTICE

If the regulator cover screw is not in place and tight, the appliance will not function properly.

20. Turn the power switch to the "OFF" position.
21. Turn the gas valves and the manual gas cock knob to the "OFF" position.
22. Remove the gas pressure fitting from the gas valve and replace with the 1/8" hex plug (removed in Step 10) and tighten.
23. Ensure that the chamber pressure reference hose is properly connected to the gas valve.
24. Turn the gas valve knobs to the "ON" position.
25. Turn the power switch to the "ON" position and replace the jacket panel. The appliance is now ready to operate.

If manifold pressure cannot be properly maintained, check the gas supply pressure with a manometer connected to the inlet pressure tap on the gas control.

TABLE - 3E NET MANIFOLD PRESSURE Regulator Pressure Less Front Chamber Pressure	
Type of Gas	Net Manifold Pressure Setting
Natural Gas	1.8" w.c.
LP Gas	4.6" w.c.

NOTICE

The front chamber pressure must be subtracted from the gross regulator pressure to obtain actual net manifold pressure for normal operation. The front chamber pressure may vary based on elevation, stages of operation, vent length and model. For information on chamber pressure, see the Maintenance section for *Combustion Air Shutter Adjustment* in this manual.

17. If adjustment is necessary, remove the regulator cover screw on the gas valve (FIG. 3-2).
18. Turn the regulator adjustment screw clockwise to raise regulator gas pressure, counterclockwise to lower the regulator gas pressure. Turn the regulator adjustment screw a 1/4 turn in the desired rotation and cycle the burners on in the sequence listed in this section and record the observed chamber and regulator settings. Subtract to determine the net manifold pressure setting. Repeat as necessary to achieve the specified net manifold pressure setting.

3 Troubleshooting

Checking gas supply pressure

1. Turn the main power switch to the "OFF" position.
2. Shut off gas supply at the field installed manual gas cock in the gas piping to the appliance. If fuel supply is LP gas, shut off gas supply at the tank.
3. On ER152 - ER202 models remove the 1/8" hex plug, located on the "inlet" side of the gas valve. An inlet pressure tapping is located on the top side of the valve body (see FIG. 3-3).

On ER252 - ER402 models remove the 1/8" hex plug, located in the tee between the low gas pressure switch and the gas valve (see FIG. 3-4).

A tapping on the field installed main manual gas cock may also be used. Install a fitting in the inlet pressure tapping suitable to connect to a manometer or magnahelic gauge. Range of scale should be 14" w.c. or greater to check inlet pressure.

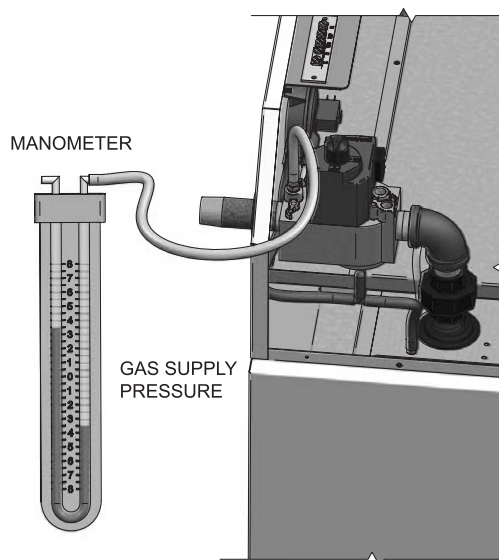

Figure 3-3_Gas Supply Pressure Measurement - Models ER152 - ER202

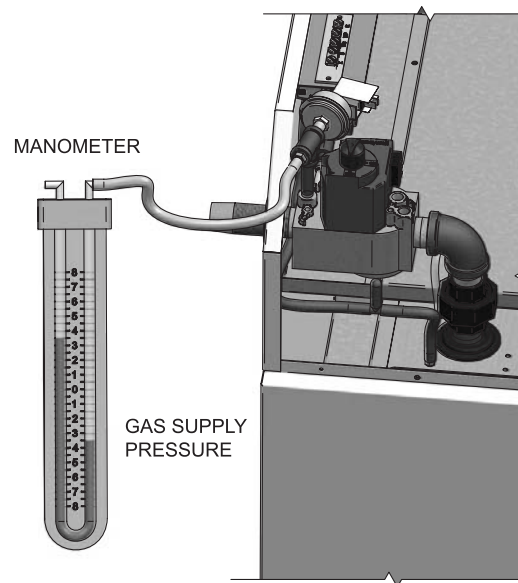

Figure 3-4_Gas Supply Pressure Measurement - Models ER252 - ER402

4. Turn on gas supply at the manual gas cock, turn on LP gas at tank if required.
5. Turn the power switch to the "ON" position.
6. Ensure that the "ON/OFF" knob or the valve is in the "ON" position.
7. Set the electronic temperature control to call for heat.
8. Observe the gas supply pressure as all burners are firing. Ensure that inlet pressure is within the specified range. Minimum and maximum gas supply pressures are specified in the *Gas Supply* section of the EnergyRite Installation and Operation Manual.
9. If gas pressure is out of range, contact a gas utility, gas supplier, qualified installer, or service agency to determine necessary steps to provide proper gas pressure to the control.
10. If the gas supply pressure is within normal range, proceed to remove gas manometer and replace pressure tap fittings in the gas control.
11. Turn the power switch to the "OFF" position.
12. Shut off gas supply at the manual gas cock in the gas piping to the appliance. If fuel supply is LP gas, shut off gas supply at the tank.

3 Troubleshooting *(continued)*

13. Remove the manometer and related fittings from the “inlet” side of the gas valve, replace the 1/8" hex plug in the tee (Models ER252 - ER402) or gas valve (Models ER152 - ER202) and tighten.
14. Turn on the gas supply at the manual valve, turn on the LP gas at the tank if required.
15. Turn the power switch to the “ON” position.
16. Ensure that the “ON/OFF” knob or the valve is in the “ON” position.
17. Set the electronic temperature control to call for heat.

If proper ignition and burner operation is not achieved after checking gas supply pressure and setting the correct net manifold pressure, see the Maintenance section for *Combustion Air Shutter Adjustment* in this manual. Follow the procedure to adjust the combustion air fan.

NOTICE

Upon completion of any testing on the gas system, leak test all gas connections with a soap and water solution while main burners are operating. Do not spray soap and water solution on the housing. The use of an excessive amount of soap and water solution can damage the control. Immediately repair any leak found in the gas train or related components. Do not operate an appliance with a leak in the gas train, valves, or related piping.

Check burner performance by cycling the system while you observe burner response. Burners should ignite promptly. Flame pattern should be stable, see the *Maintenance Normal Flame Pattern* section. Turn system off and allow burners to cool, then cycle burners again to ensure proper ignition and flame characteristics.



*ERP-SER-Rev A
CP-2M-3/07*