

MEGATHERM® HIGH PERFORMANCE GAS FIRED COMMERCIAL POOL HEATER



Powerful, efficient, and reliable, MegaTherm pool heaters are designed for commercial, institutional and large residential pools where economical performance and rapid heat-up are required. Available in indoor and outdoor models, with twenty-two sizes from 500,000 to 5,000,000 BTU/h to precisely match any heating requirement.

MegaTherm heaters are designed to deliver efficiencies as high as 82%. Integral finned copper tubes are rolled directly into the headers, and conformal heat exchanger baffles and an eight-fins-per-inch tubing configuration maximize combustion heat extraction. We've also designed the MegaTherm

heater to be simple to service. Heat exchanger header covers are field-removable for complete inspection of tubing and header passages, and the heat exchanger is replaceable without disassembly of the burners or combustion chamber.

MegaTherm heaters are design certified to the ANSI® Z21.56 Standard for Gas-Fired Pool Heaters. (Outdoor 500-1825 units are certified for use without the addition of a draft diverter or external vent. Indoor units incorporate a built-in draft diverter and require only vent piping.) Salt water models (500-1825) are available with cupronickel alloy heat exchanger tubes and header covers.

STANDARD FEATURES

- Reliable operation on natural or propane gas.
- Electronic ignition.
- Built-in draft diverter (indoor models) simplifies installation.
- Flow switch standard on all models.
- Integral pump assures proper water flow (Models 500-1825).
- Automatic gas valve.
- Stainless steel burners, with slide-out burner tray for easy maintenance and long life (Models 500-1825).
- Galvanized steel jacket with acrylic finish for strength and durability.
- High temperature refractory firebox liner to 2000° F for greater efficiency.
- Easy-to-service header flanges.
- Corrosion-resistant glass-lined headers.
- Integral lined copper tube heat exchanger for higher efficiency.
- Electronic temperature control for accuracy. (Models 500-1825; model configuration varies slightly by size.)
- One-year limited warranty. See warranty for details.

MEGATHERM®

HIGH PERFORMANCE GAS FIRED COMMERCIAL POOL HEATER

Dimensional and Sizing Data

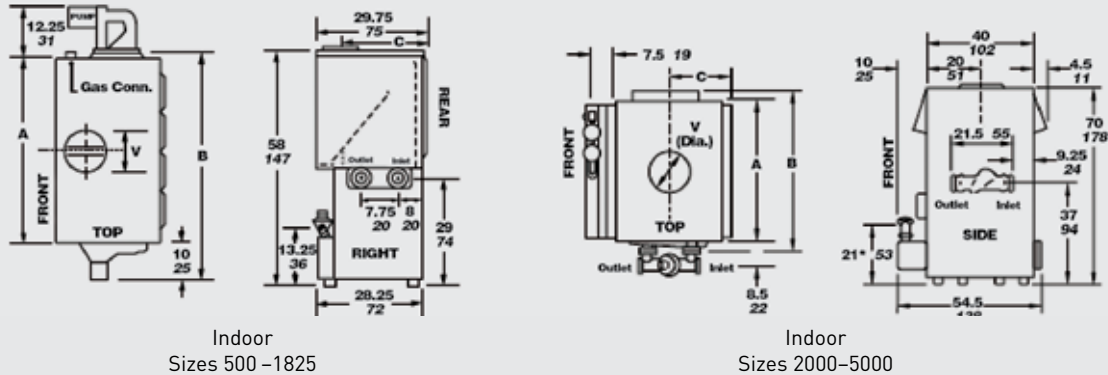

FOR INDOOR POOLS MODEL I

1. Calculate the surface area of the pool in square feet.
2. Refer to the selection chart for either an indoor or outdoor heater.
3. Find the closest square footage in the 10° F (6° C) Temperature Difference column, and the heater models which correspond to it. For normal conditions, Pentair recommends using the 10° F Temperature Difference columns; this will provide a temperature increase of approximately 6° F per 24 hour period.

Temperature Difference

Model	10° F	6° C	15° F	8° C	20° F	11° C	25° F	14° C	30° F	17° C	35° F	19° C	40° F	22° C	45° F	25° C	50° F	28° C	
	Surface Area of Pools (Sq. Ft.)																		
500 I	3900	362	2600	242	1950	181	1560	145	1300	121	1115	104	975	91	870	81	780	72	
600 I	4680	435	3120	290	2340	217	1870	174	1560	145	1340	124	1170	109	1040	97	935	87	
715 I	5580	518	3720	346	2790	259	2230	207	1860	173	1595	148	1395	130	1240	115	1115	104	
850 I	6630	616	4420	411	3315	308	2650	246	2210	205	1895	176	1660	154	1475	137	1325	123	
1010 I	7880	732	5250	488	3940	366	3150	293	2625	244	2259	210	1970	183	1750	163	1575	146	
1200 I	9360	870	6240	580	4680	435	3745	348	3120	290	2675	249	2340	217	2080	193	1870	174	
1430 I	11155	1036	7435	691	5580	518	4460	414	3720	346	3190	296	2790	259	2480	230	2230	207	
1670 I	13025	1210	8685	807	6515	605	5210	484	4340	403	3720	346	3260	303	2895	269	2605	242	
1825 I	14235	1322	9490	882	7120	661	5695	528	4745	441	4070	378	3560	331	3165	294	2850	265	
2000 I	16400	1524	10935	1016	8200	819	6560	609	5465	508	4685	435	4100	381	3645	339	3280	305	
2450 I	20090	1866	13395	1244	10045	933	8035	746	6695	622	5740	533	5025	467	4465	415	4020	373	
3050 I	25010	2323	16675	1549	12505	1162	10000	929	8335	744	7145	664	6255	581	5560	517	5000	465	
3500 I	28700	2666	19135	1778	14350	1333	11480	1066	9565	889	8200	764	7175	667	6380	593	5740	533	
4050 I	33210	3085	22140	2057	16605	1543	13285	1234	11070	1028	9490	882	8300	771	7380	686	6640	617	
4500 I	36900	3428	24600	2285	18450	1714	14760	1371	12300	1143	10545	980	9225	857	8200	762	7380	686	
5000 I	41000	3809	27335	2539	20500	1904	16400	1524	13665	1269	11715	1088	10250	952	9110	846	8200	762	

Dimensional Data

Indoor Size	Input ₁		Output ₁		Gas Conn. Size ₂ - inches NPT		Water Conn. Size ₂ - inches NPT	Dimensions ₂ - inches cm						Weight ₃			
	MBTU/h	kw	MBTU/h	kw	Nat	LP		A	B	C	V	lbs.	kg				
500 I	500	147	405	119	1	3/4	2 1/2	33 3/4	86	45 1/4	115	23 3/4	60	10	25	808	367
600 I	600	176	486	143	1	3/4	2 1/2	38 3/4	98	50 1/4	128	22 3/4	58	12	30	819	372
715 I	715	210	579	170	1	3/4	2 1/2	44 1/4	112	55 3/4	142	22 3/4	58	12	30	873	396
850 I	850	249	689	202	1	3/4	2 1/2	50 3/4	129	62 1/4	158	21 3/4	55	14	36	945	429
1010 I	1010	296	818	240	1 1/4	1	2 1/2	58	147	69 1/2	177	20 3/4	53	16	41	1041	473
1200 I	1200	352	972	285	1 1/4	1	2 1/2	66 1/4	168	77 3/4	197	20 3/4	53	16	41	1199	544
1430 I	1430	419	1158	339	1 1/4	1 1/4	2 1/2	76	193	87 1/2	222	19 3/4	50	18	46	1280	581
1670 I	1670	489	1353	396	1 1/2	1 1/4	2 1/2	85 1/2	217	97	246	19 3/4	50	18	46	1445	656
1825 I	1825	535	1478	433	1 1/2	1 1/4	2 1/2	92 1/2	235	103 3/4	264	19 3/4	50	18	46	1570	713
2000 I	2000	586	1639	480	1 1/2	1 1/4	4	55 1/2	141	73	185	24 1/2	62	22	56	1950	885
2450 I	2450	718	2009	589	1 1/2	1 1/2	4	65 1/2	166	83	211	24 1/2	62	24	61	2100	913
3050 I	3050	894	2501	733	2	1 1/2	4	78	198	95 1/2	243	24 1/2	62	26	66	2250	1022
3500 I	3500	1025	2870	841	2	1 1/2	4	88	224	105 1/2	268	24 1/2	62	28	71	2510	1140
4050 I	4050	1186	3321	973	2	2	4	100 1/2	255	118	300	24 1/2	62	30	76	2750	1249
4500 I	4500	1318	3690	1081	2 1/2	2	4	110 1/2	281	128	325	24 1/2	62	32	81	2900	1317
5000 I	5000	1465	4100	1201	2 1/2	2	4	123	312	140 1/2	357	24 1/2	62	34	86	3200	1453

- NOTES:
1. Input and output must be derated 4% per 1000 feet above sea level when installed above 2000 feet altitude.
 2. Dimensions are nominal.
 3. Integral pump included on sizes 500-1825.

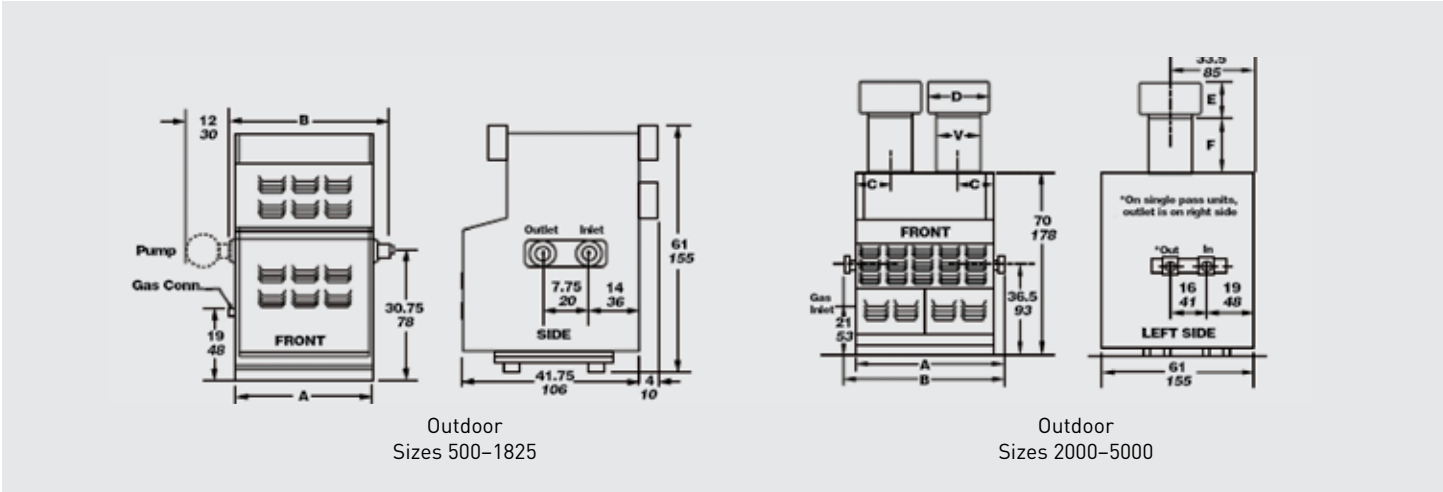

FOR OUTDOOR POOLS MODEL E

1. Determine the difference between the desired pool temperature and the average air temperature during the coldest month in which the pool will be used (referred to in the chart below as "Temperature Difference").
2. Calculate the surface area of the pool.
3. Refer to the selection chart. Listed are the maximum pool surface areas for each heater model with typical temperature differences. Make the appropriate selection from the chart.

Temperature Difference

Model	10° F	6° C	15° F	8° C	20° F	11° C	25° F	14° C	30° F	17° C	35° F	19° C	40° F	22° C	45° F	25° C	50° F	28° C
	Surface Area of Pools (Sq. Ft.)																	
500 E	4000	372	2665	248	2000	186	1600	149	1330	124	1140	106	1000	93	885	82	800	74
600 E	4800	446	3200	297	2400	223	1920	178	1600	149	1370	127	1200	111	1065	99	960	89
715 E	5720	531	3810	354	2860	266	2285	212	1905	177	1630	151	1430	133	1270	118	1140	106
850 E	6800	632	4530	421	3400	316	2720	253	2265	210	1940	180	1700	158	1510	140	1360	126
1010 E	8080	751	5385	500	4040	375	3230	300	2690	250	2305	214	2020	188	1795	167	1615	150
1200 E	9600	892	6400	595	4800	446	3840	357	3200	297	2740	255	2400	223	2130	198	1920	178
1430 E	11440	1063	7625	708	5720	531	4575	425	3810	354	3265	303	2860	266	2540	236	2285	212
1670 E	13360	1241	8905	827	6680	621	5344	496	4450	413	3815	354	3340	310	2965	275	2670	248
1825 E	14600	1356	9730	904	7300	678	5840	543	4865	452	4170	387	3650	339	3240	301	2920	271
2200 E	17861	1659	11907	1106	8930	830	7144	664	5954	553	5103	474	4465	415	3969	369	3572	332
2800 E	22235	2066	14823	1377	11117	1033	8894	826	7412	689	6353	590	5559	516	4941	459	4447	413
3200 E	25515	2370	17010	1580	12758	1185	10206	948	8505	790	7290	677	6379	593	5670	527	5103	474
3600 E	29525	2743	19683	1829	14762	1371	11810	1097	9842	914	8436	784	7381	686	6561	610	5905	549
4000 E	32805	3048	21870	2032	16403	1524	13122	1219	10935	1016	9373	871	8201	762	7290	677	6561	610
4500 E	36450	3386	24300	2257	18225	1693	14580	1354	12150	1129	10414	967	9113	847	8100	752	7290	677

NOTES: For high altitude pools, reduce the surface area figures shown in the charts by 4% for each 1000 ft. above sea level. (No derating is necessary up to 2000 ft. above sea level.)
Sizing for outdoor pools is based on 3 1/2 mph average wind.

Dimensional Data

Indoor Size	Input ₁		Output ₁		Gas Conn. Size ₂ inches NPT		Water Conn. Size ₂ - inches NPT	Dimensions ₂ - inches cm											Outdoor Size	Shipping Weight ₃	
	MBTU/h	kw	MBTU/h	kw	Nat	LP		A	B	C	D	E	F	V	lbs.	kg					
500 E	500	147	410	120	1	3/4	2 1/2	33 3/4	86	45 1/4	115	-	-	-	-	-	-	-	500 E	500	147
600 E	600	176	492	144	1	3/4	2 1/2	38 3/4	98	50 1/4	128	-	-	-	-	-	-	-	600 E	600	176
715 E	715	210	586	172	1	3/4	2 1/2	44 1/4	112	55 1/4	142	-	-	-	-	-	-	-	715 E	715	210
850 E	850	249	697	204	1	3/4	2 1/2	50 3/4	129	62 1/4	158	-	-	-	-	-	-	-	850 E	850	249
1010 E	1010	296	828	243	1 1/4	1	2 1/2	58	147	69 1/2	177	-	-	-	-	-	-	-	1010 E	1010	296
1200 E	1200	352	984	288	1 1/4	1	2 1/2	66 1/4	168	77 3/4	197	-	-	-	-	-	-	-	1200 E	1200	352
1430 E	1430	419	1173	344	1 1/4	1 1/4	2 1/2	76	193	87 1/2	222	-	-	-	-	-	-	-	1430 E	1430	419
1670 E	1670	489	1370	401	1 1/2	1 1/4	2 1/2	85 1/2	217	97	246	-	-	-	-	-	-	-	1670 E	1670	489
1825 E	1825	535	1497	439	1 1/2	1 1/4	2 1/2	92 1/2	235	103 3/4	264	-	-	-	-	-	-	-	1825 E	1825	535
2200 E	2205	646	1786	523	1 1/2	1 1/4	4	65 1/2	166	83	211	16	41	28 1/4	72	15	38	24	61	18	46
2800 E	2745	804	2223	651	1 1/2	1 1/2	4	78	198	95 1/2	243	20	51	28 1/4	72	15	38	24	61	18	46
3200 E	3150	923	2552	748	2	1 1/2	4	88	224	105 1/2	268	23	58	31 1/2	80	16 1/2	42	36	91	20	51
3600 E	3645	1068	2952	865	2	2	4	100 1/2	255	118	300	29	74	31 1/2	80	16 1/2	42	36	91	20	51
4000 E	4050	1187	3281	961	2 1/2	2	4	110 1/2	281	128	325	30 1/2	77	34 1/2	88	18	46	36	91	22	56
4500 E	4500	1319	3645	1068	2 1/2	2	4	123	312	140 1/2	357	34	86	37 3/4	96	19 1/2	50	36	91	24	61

NOTES: 1. Input and output must be derated 4% per 1000 feet above sea level when installed above 2000 feet altitude.
2. Dimensions are nominal.
3. Integral pump included on sizes 500-1825.

MEGATHERM®

HIGH PERFORMANCE GAS FIRED COMMERCIAL POOL HEATER

THE PERFECT COMBINATION OF ACCURATE CONTROL, EFFICIENCY, AND LONG LIFE

The MegaTherm heater is packed with performance features designed specifically for the commercial, institutional, and large residential pool market. The primary/secondary pump and control (Models 500–1825) feature an electronic controller with a solid state sensor and adjustable differential for accurate temperature control. Inlet water is preheated to eliminate condensation, and a constant velocity in the heat exchanger increases tube life. The diverter valve has been eliminated in the pool circulation line, resulting in lower installation and operating costs. And, inlet and outlet thermometers with ±1% accuracy allow precise set-up and temperature rise monitoring.

Additional Design Advantages Include:

- Control system includes automatic temperature control, temperature limit, gas pressure regulator, redundant electric gas valve, water flow sensing, electronic flame safety supervision and manual gas shut-off valve. The standard control system operates on 24 VAC with a 120 VAC power supply. Standard units are intermittent (spark) ignition.
- Working pressure of 160 psi complies with Section IV of the ASME® Boiler and Pressure Vessel Code. Units are registered with the National Board of Boiler and Pressure Vessel Inspectors.
- Pressure relief valve is ASME rated and is selected to provide discharge capacity in excess of unit heating input.
- Combustion chamber is cast refractory with a 2000° F (1093° C) working temperature.
- Burners are atmospheric type constructed of AISI alloy 430 (models 500–1825) or AISI 439 (models 2000–5000) stainless steel.
- Chassis and jacket parts are of galvanized steel meeting ASTM® Standard for G90 coating. Exterior is finished with acrylic paint, thermoset at 325° F (163° C).
- Integral flow control valve on models 2000–5000 accepts flows up to 300 GPM.

Part Numbers	Descriptions
MT0500IN09C1PC	Indoor, Spark Ignition, On-Off, Pump Mtd., Cl-Cu HX, Std. Unit, Nat. Gas
MT0600IN09C1PC	Indoor, Spark Ignition, On-Off, Pump Mtd., Cl-Cu HX, Std. Unit, Nat. Gas
MT0715IN09C1PC	Indoor, Spark Ignition, On-Off, Pump Mtd., Cl-Cu HX, Std. Unit, Nat. Gas
MT0850IN09C1PC	Indoor, Spark Ignition, On-Off, Pump Mtd., Cl-Cu HX, Std. Unit, Nat. Gas
MT0999IN09C1PC	Indoor, Spark Ignition, On-Off, Pump Mtd., Cl-Cu HX, Std. Unit, Nat. Gas
MT1010IN09C1PC	Indoor, Spark Ignition, On-Off, Pump Mtd., Cl-Cu HX, Std. Unit, Nat. Gas
MT1200IN09C1PC	Indoor, Spark Ignition, On-Off, Pump Mtd., Cl-Cu HX, Std. Unit, Nat. Gas
MT1430IN09C1PC	Indoor, Spark Ignition, On-Off, Pump Mtd., Cl-Cu HX, Std. Unit, Nat. Gas
MT1670IN09CBPC	Indoor, Spark Ignition, On-Off, Pump Mtd., Cl-Cu HX, Std. Unit, Nat. Gas
MT1825N09CBPC	Indoor, Spark Ignition, On-Off, Pump Mtd., Cl-Cu HX, Std. Unit, Nat. Gas
MT2000IN18CCAC	Indoor, Spark Ignition, Less Pump, Cl-Cu HX, Std. Unit, Nat. Gas
MT2450IN18CCAC	Indoor, Spark Ignition, Less Pump, Cl-Cu HX, Std. Unit, Nat. Gas
MT3050IN18CCAC	Indoor, Spark Ignition, Less Pump, Cl-Cu HX, Std. Unit, Nat. Gas
MT3500IN18CCAC	Indoor, Spark Ignition, Less Pump, Cl-Cu HX, Std. Unit, Nat. Gas
MT4050IN18CCAC	Indoor, Spark Ignition, Less Pump, Cl-Cu HX, Std. Unit, Nat. Gas
MT4500IN18CCAC	Indoor, Spark Ignition, Less Pump, Cl-Cu HX, Std. Unit, Nat. Gas
MT5000IN18CCAC	Indoor, Spark Ignition, Less Pump, Cl-Cu HX, Std. Unit, Nat. Gas
MT2200EN18CCAC	Outdoor, Spark Ignition, Less Pump, Cl-Cu HX, Std. Unit, Nat. Gas
MT2800EN18CCAC	Outdoor, Spark Ignition, Less Pump, Cl-Cu HX, Std. Unit, Nat. Gas
MT3200EN18CCAC	Outdoor, Spark Ignition, Less Pump, Cl-Cu HX, Std. Unit, Nat. Gas
MT3600EN18CCAC	Outdoor, Spark Ignition, Less Pump, Cl-Cu HX, Std. Unit, Nat. Gas
MT4000EN18CCAC	Outdoor, Spark Ignition, Less Pump, Cl-Cu HX, Std. Unit, Nat. Gas
MT4500EN18CCAC	Outdoor, Spark Ignition, Less Pump, Cl-Cu HX, Std. Unit, Nat. Gas
MT2200EN18CCAN	Outdoor, Spark Ignition, Less Pump, Cl-Cu-Ni HX, Std. Unit, Nat. Gas
MT2800EN18CCAN	Outdoor, Spark Ignition, Less Pump, Cl-Cu-Ni HX, Std. Unit, Nat. Gas
MT3200EN18CCAN	Outdoor, Spark Ignition, Less Pump, Cl-Cu-Ni HX, Std. Unit, Nat. Gas
MT3600EN18CCAN	Outdoor, Spark Ignition, Less Pump, Cl-Cu-Ni HX, Std. Unit, Nat. Gas
MT4000EN18CCAN	Outdoor, Spark Ignition, Less Pump, Cl-Cu-Ni HX, Std. Unit, Nat. Gas
MT4500EN18CCAN	Outdoor, Spark Ignition, Less Pump, Cl-Cu-Ni HX, Std. Unit, Nat. Gas

Cupro-nickel alloy heat exchanger models and CSO-1 models are available. Contact the factory for part numbers.



1620 HAWKINS AVE, SANFORD, NC 27330 800.831.7133 WWW.PENTAIRCOMMERCIAL.COM

All Pentair trademarks and logos are owned by Pentair or one of its global affiliates. MegaTherm® is a registered trademark of Pentair Water Pool and Spa, Inc. and/or its affiliated companies in the United States and/or other countries. Because we are continuously improving our products and services, Pentair reserves the right to change specifications without prior notice. Pentair is an equal opportunity employer.

