



Hayward Commercial is ready to jump in:
1-800-657-2287
 Our toll-free line will put you in direct contact with an experienced
 technical commercial products specialist.
 We're here to serve you.



Hayward Commercial
 10101 Molecular Dr. | Suite 200 | Rockville, MD 20850
 Visit us at: www.haywardcommercialpool.com

Total System: Pumps | Filters | Heating | Cleaners | Sanitization | Automation | Lighting | Safety | White Goods | Flow Control

 Hayward is a registered trademark
 of Hayward Industries, Inc.
 © 2011 Hayward Industries, Inc.

MODEL	EFFECTIVE FILTRATION RATE		DESIGN FLOW RATE <i>Commercial</i>	
	FT2	M2	GPM	LPM
HCF7030C	700	63.2	150	568
MAXIMUM WORKING PRESSURE 50 PSI (3.45 BAR)				

ATTENTION INSTALLER: THIS MANUAL CONTAINS IMPORTANT
 INFORMATION ON THE OPERATION, AND SAFE USE OF THIS EQUIPMENT.
 THIS MANUAL IS INTENDED FOR THE END USER OF THIS PRODUCT.

Table of Contents

1. Important Safety Instructions
2. General
 - 2.1 Installation
3. Characteristics and Dimensions
 - 3.1 Before Starting the Pump
4. Operation
 - 4.1 Filtering
 - 4.2 Maintaining Your Filter
 - 4.3 Removing Cartridges
5. Filter Re-Assembly Instructions
 - 5.1 Re-Installing Cartridges
 - 5.2 Clean Seal Ring and Seal Surface
 - 5.3 Body and Clamp Re-Assembly
6. Vacuuming Pool
7. Manual Air Relief Valve
 - 7.1 Removing the Manual Air Relief Valve
 - 7.2 Re-Installation of the Manual Air Relief Valve
8. Winterizing
9. Service and Repairs
10. Replacement Part Drawings and Numbers
11. Warranty
12. Product Registration
13. Warranty Card Registration

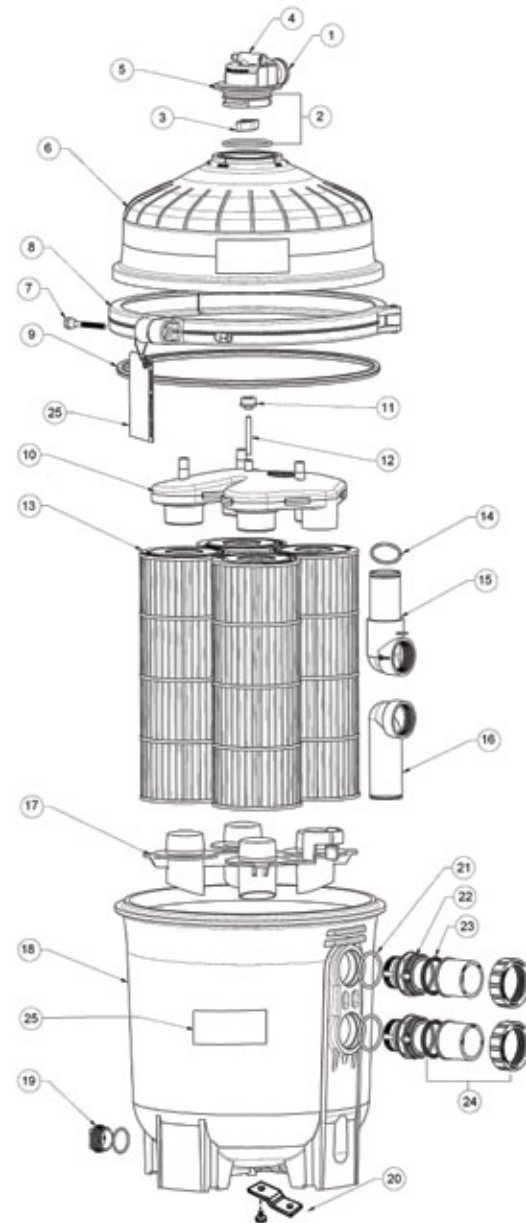

HCF Cartridge Filter

Model: HCF7030C

1. Important Safety Instructions

⚠ This is the safety-alert symbol. When you see this symbol on your pump or in this manual, look for one of the following signal words, and be alert to the potential for personal injury or death.

⚠ WARNING warns about hazards that could cause serious personal injury, death or major property damage and if ignored presents a potential hazard.

⚠ CAUTION warns about hazards that will or can cause minor or moderate personal injury and/or property damage and if ignored presents a potential hazard. It can also make consumers aware of actions that are unpredictable and unsafe.

The **NOTICE** label indicated special instructions that are important but not related to hazards.

ⓘ **⚠ WARNING – READ, UNDERSTAND, AND FOLLOW ALL SAFETY AND OPERATION INSTRUCTIONS.**
Failure to follow safety and operation instructions can result in severe personal injury or death.

⚠ CAUTION – To reduce risk of injury, do not permit children to use or climb on this product. Closely supervise children at all times. The ANSI/NSPI-4 Standard (above-ground and on-ground pools) advises that components such as the filtration system, pumps, and heaters be positioned to prevent their being used as a means of access to the pool by young children.

⚠ **⚠ WARNING – COMPONENT SEPARATION HAZARD**
Pool and spa water circulation systems operate under hazardous pressure during start up, normal operation, and possibly after pump shut off. Pressure in system can cause explosive component separation of the upper filter body if safety and operation instructions are not followed. Severe personal injury or death can result.

⚠ This product should be installed and serviced only by a qualified pool professional.

TO AVOID COMPONENT SEPARATION

- Follow all safety and operation instructions.
- Do not operate water circulation system if a system component is assembled improperly, damaged, missing, or not a genuine Hayward component.
- Before performing maintenance on the water circulation system, verify all system and pump controls are in OFF position and filter manual air relief valve is in the OPEN position.
- Use ONLY Hayward clamp system components: DEX2421JKIT clamp assembly, DEX2421J2 nut/bolt assembly, and a DEX2422Z2 metal reinforced seal.
Non-Hayward components may fail in use and cause explosive separation.
- Never rely on hand tightening the clamp nut to the clamp bolt. Using a 3/4" socket on a torque wrench, torque clamp nut and clamp bolt to 150 inch-lbs.
- Before starting system pump, insure filter manual air relief valve body is in LOCK position in filter upper body.
- Before starting the system pump, verify that all system valves are set in a position to allow water from the filter to return back to the pool.
- Before starting the system pump, the manual air relief valve must be in the OPEN position.
- When starting pump, do not stand over or near filter.
- If water leakage appears in the area of the filter tank clamp, immediately turn off all system circulation pumps and electrical power. Do not return to the filter until all water flow has stopped. Reassemble the clamp system per the instructions in this owner's manual to stop the leak.
- Return to filter to close manual air relief valve only when a steady stream of water (Not air or air and water mix) is discharged from the manual air relief valve.
- Do not change filter control valve position while system pump is running.

⚠ **⚠ WARNING – EXCESS PRESSURE HAZARD**
Pressure testing of the pump and filter system in excess of the 50 PSI can cause explosive separation of the components. Component separation can result in severe personal injury or death.



⚠ WARNING – ELECTROCUTION HAZARD. High voltage electricity is present in the pool and spa equipment. High voltage electricity can cause shock and electrocution. Shock and electrocution can result in severe personal injury or death.

- All electrical wiring **MUST** be in conformance with applicable local codes, regulations and the National Electrical Code (NEC).
- Before performing any service or maintenance on electrical equipment turn off all electrical power.
- Contact a licensed electrician or building inspector for information on local electrical codes for bonding requirements.
- Verify water discharge from the filter manual air relief valve is directed away from electrical devices.
- Do not locate pump controls over or near filter.



⚠ WARNING – SUCTION ENTRAPMENT HAZARD.

Suction in suction outlets and/or suction outlet covers that are, damaged, broken, cracked, missing, or unsecured can cause severe injury and/or death due to the following entrapment hazards:



Hair Entrapment – Hair can become entangled in suction outlet cover.



Limb Entrapment – A limb inserted into an opening of a suction outlet sump or suction outlet cover that is damaged, broken, cracked, missing, or not securely attached can result in a mechanical bind or swelling of the limb.



Body Suction Entrapment – A negative pressure applied to a large portion of the body or limbs can result in an entrapment.



Evisceration/ Disembowelment Entrapment – A negative pressure applied directly to the intestines through an unprotected suction outlet sump or suction outlet cover that is, damaged, broken, cracked, missing, or unsecured can result in evisceration/ disembowelment entrapment.

Mechanical Entrapment – There is potential for jewelry, swimsuit, hair decorations, finger, toe or knuckle to be caught in an opening of a suction outlet cover resulting in mechanical entrapment.

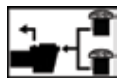

⚠ WARNING – To Reduce the Risk of Entrapment Hazards:

- A minimum of two functioning suction outlets per pump must be installed. Suction outlets in the same plane (i.e. floor or wall), must be installed a minimum of three feet (3') [1 meter] apart, as measured from near point to near point.
- Dual suction outlets shall be placed in such locations and distances to avoid “dual blockage” by a user.
- Dual suction outlets shall not be located on seating areas or on the backrest for such seating areas.
- The pool or spa circulation system shall be designed to comply with ANSI/APSP-7 2006.
- Suction outlet covers shall conform to ANSI/ASME A112.19.8
- Never use Pool or Spa if any suction outlet component (cover/grate) is damaged, broken, cracked, missing, or not securely attached.
- Immediately replace damaged, broken, cracked, missing, or not securely attached suction outlet components.
- The CPSP as well as the ICC International Residential Code Part IX, Appendix G, Section AG106 specifies the installation of a safety vacuum release system conforming to ASME A112.19.17, or an approved gravity drain system.
- Failure to remove pressure test plugs and/or plugs used in winterization of the pool/spa from the suction outlets can result in an increased potential for suction entrapment.
- Failure to keep suction outlet components clear of debris, such as leaves, dirt, hair, paper and other material can result in an increased potential for suction entrapment.

Suction outlet covers and grates have a finite life. They should be inspected frequently and replaced within specified life.

2. General Information

Your Hayward HCF cartridge filter combines superior water filtration with ease of operation and totally corrosion-resistant construction. With filtration ratings to 9000 gallons (34,000 liters) per hour, they are designed for continuous or intermittent operation, for installation above or below the pool water line, for fresh or salt water swimming pools or spas. HCF filters utilize multiple reusable, reinforced polyester filter cartridge elements to provide a high degree of water clarity and long filter cycles with minimum care.

	A		REQUIRED CLEARANCE			
			"F" SIDE		"B" ABOVE	
	IN	CM	IN	CM	IN	CM
HCF7030C	52.5	133	18	46	28	71

2.1 Installation



This product should be installed and serviced only by a qualified pool professional.

1. The filter system should be installed on a level concrete slab or other rigid base. Select a well drained and vented area, one that does not flood when it rains. Position the filter so that the piping connections, and winter drain are convenient and accessible for operation, service, maintenance and winterizing.
2. Position filter body such that all operation and safety labels are visible.
3. Position filter so the filter will drain by gravity.
4. If practical, place pump and filter in the shade to shield it from continuous, direct heat from the sun.
5. Connect the pool suction plumbing between the skimmer, pool suction outlet (from the pool) and the pump.
6. Connect the pump discharge to the bottom port of the filter. FROM THE PUMP (INLET) is the bottom port.
7. Install the plumbing from the filter (OUTLET) (return to the pool) to the pool (Top Port).
8. Do not locate pump controls over or near filter.
9. Verify water discharge from the manual air relief valve(MAR) is directed away from electrical devices.

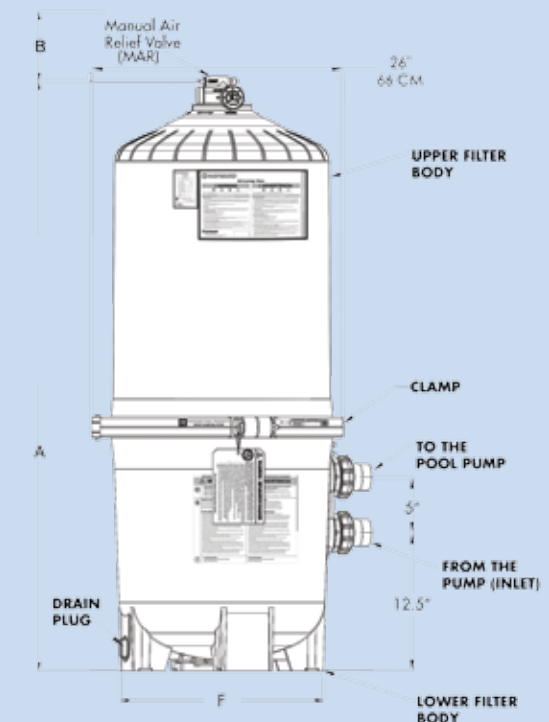

3. Starting the Pump and Filter System

⚠ **WARNING** 

3.1 Before Starting the Pump

1. Use ONLY Hayward clamp system components; DEX2421JKIT clamp system, DEX2421J2 nut/bolt assembly, DEX2422Z2 metal reinforced seal. Non-Hayward clamp components may fail in use and cause explosive component separation. Verify that upper and lower filter bodies are properly secured with the filter body clamp. Never rely on hand tightening the clamp nut to the clamp bolt. Using a 3/4" socket on a torque wrench, torque clamp nut to clamp bolt to 150 inch-lbs. (See Fig 1) Verify that the filter manual air relief body is in the LOCK position, and no filter components are missing, damaged or not genuine Hayward components. (See Fig 2)
2. Close filter drain. NOTE: Filter plug requires an o-ring seal. (See Fig 4)
3. Open all system valves to allow water from the pool to the filtration system and from the filter to return to the pool.
4. Place the manual air relief valve in OPEN position. (See Fig 2)

3.2 Starting the Pump

1. When starting system pump, do not stand over or near filter. If water leakage appears at filter tank clamp, immediately turn off all system circulation pumps and all electrical power. Do not return to the filter until all water leakage has stopped. Reassemble the clamp system per the instructions on page 7 in this owner's manual to stop leak.
2. Return to filter to CLOSE manual air relief valve only when a steady stream of water (not air or, air and water mix) is discharged from the manual air relief valve.

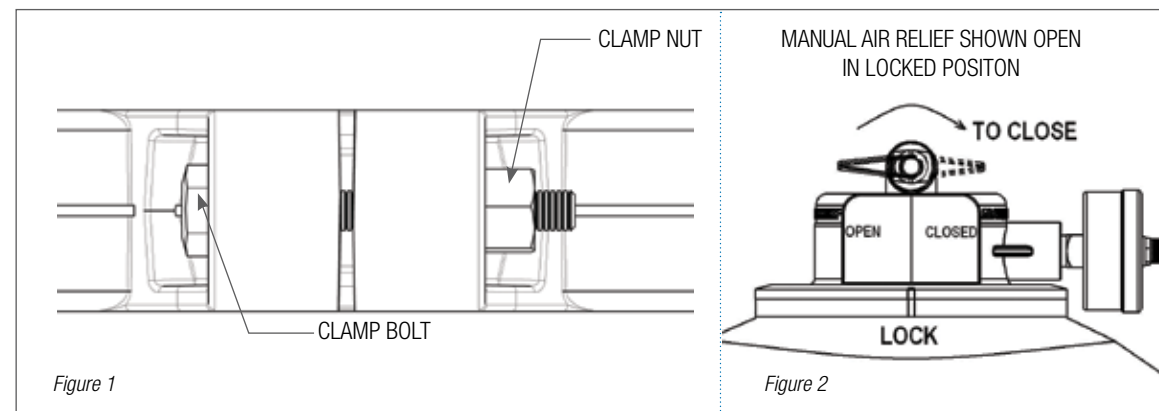

Figure 1

Figure 2

4. Operation

4.1 Filtering

⚠ **WARNING** 

Filtration starts as soon as flow is steady through the filter. As the filter removes dirt from the pool water, the accumulated dirt causes a resistance to flow. As a result, the gauge pressure will rise and the flow will decrease. When the pressure rises between 7 and 10 psi (.49 - .69 bar) above the starting pressure, or when the flow decreases below the desired rate, clean or replace the filter cartridge elements. Once your filter is running and there is a pressure reading, line up the green arrow with the current reading. (See Fig 3) When the pressure rises to or above the red or second arrow, it is time to clean or replace your filter cartridge elements.

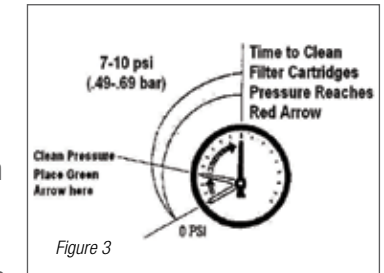

Figure 3

By recording the initial starting pressure (with clean filter elements) a determination can be made when the filter cartridge elements should be replaced rather than cleaned. After the filter elements have been cleaned and reinstalled if the starting pressure is higher than 6 PSI above the starting pressure with the new filter cartridge elements, the filter cartridge elements should be replaced the next time the gauge arrow reaches the red arrow.

4.2 Maintaining Your Filter

⚠ **WARNING** 

⚠ **WARNING:** This product should be installed and serviced only by a qualified pool professional.

FILTER DISASSEMBLY INSTRUCTIONS

1. Turn off all system circulation pumps and all electric power on the equipment pad.
2. Set all system valves in a position to prevent water flow to the filter.
3. The manual air relief valve must be placed in the OPEN position. (Fig 6)
4. Remove filter drain plug (Fig 4) and drain water from filter.
5. Using 3/4" wrenches or hex sockets, loosen and remove the clamp nut and the clamp bolt. (Fig 5)
6. Holding both ends of the filter clamp carefully spread the clamp ends. Remove the clamp by lifting over the upper filter body. Do not to drop the clamp during removal, because the clamp could be damaged. Do not strike the clamp with metal tools as they can damage the clamp.
7. Lift off upper filter body. Do not use the pressure gauge to lift the upper filter body.

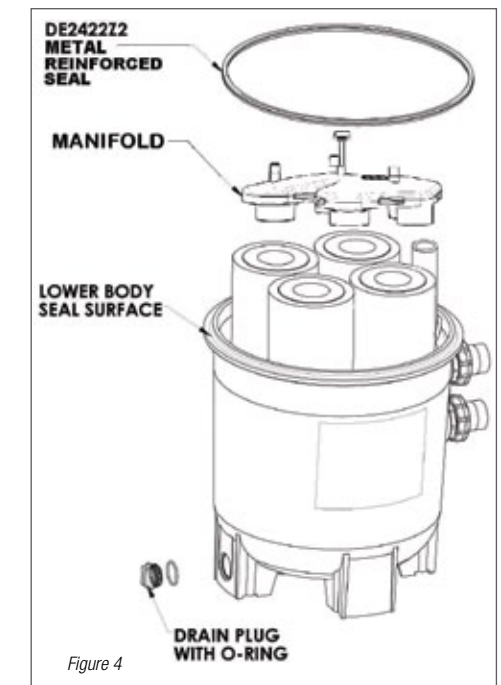
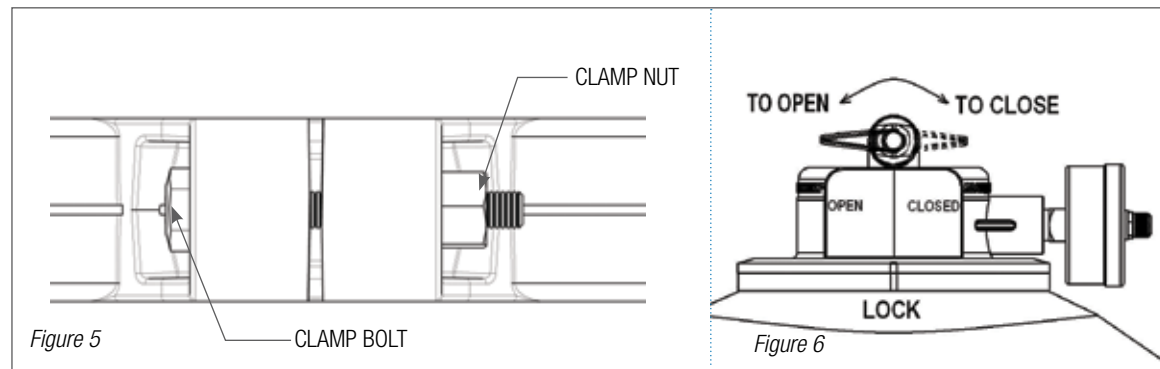

Figure 4



4.3 Removing Cartridges

1. Remove the top Manifold, which is exposed when the upper filter body is removed. (Fig 4)
2. Remove the filter cartridge elements by using slight rocking motion and lifting up.
3. Clean filter cartridge elements.

4.4 Cleaning Cartridges

The Cartridge filter element can be cleaned by washing inside and outside with a garden hose. After hosing cartridge, for best results, carefully brush the pleated surface to remove fine particles. Do not pressure wash as it can damage the filter element.

You may find some debris on the cartridge pleats, which may not have been removed with hosing.

5. Filter Re-Assembly Instructions

5.1 Re-Installing Cartridges

⚠ WARNING

1. Flush and drain any dirt or debris from the bottom of the lower filter body.
2. Flush any dirt or debris from the upper filter body and from around the manual air relief area.
3. Carefully replace the cartridges over the hubs on the bottom seal plate.
4. Place top manifold securely on top of cartridges, aligning the return pipe with the port in the manifold.

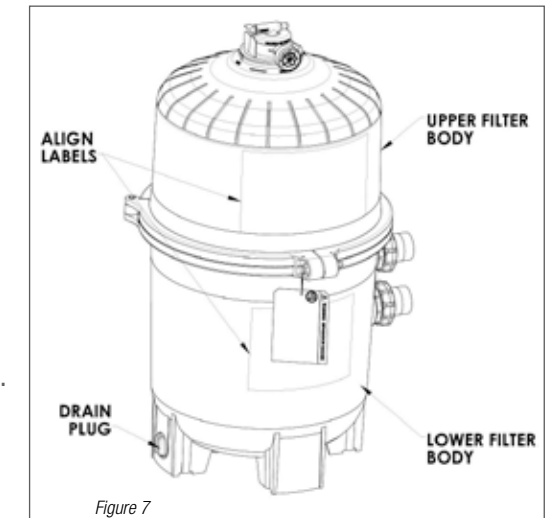

5.2 Clean Seal Ring and Seal Surface

1. Remove filter tank seal.
2. With a clean cloth, wipe the lower filter body seal surface and clean seal of all dirt and debris. (Fig 4) Do not use a solvent.
3. With a clean cloth wipe the upper filter body seal surface.

⚠ NOTICE:

- Do not use any petroleum solvents to clean filter components.
- Do not lubricate DEX2422Z2 seal.

⚠ WARNING

⚠ WARNING: This product should be installed and serviced only by a qualified pool professional.

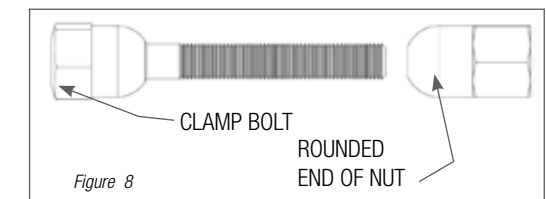

5.3 Body and Clamp Re-Assembly

1. Place the metal reinforced seal on lower filter body. (Fig 4) Place upper filter body on metal reinforced seal and lower filter body in a position which allows all operation and safety labels to be clearly visible and the upper filter body to be centered on the lower filter body. Press down firmly and evenly on the upper filter body to seat the seal. (Fig 7)

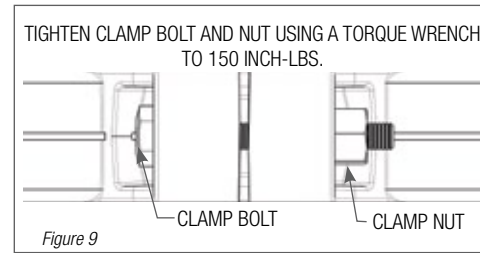

2. Replace the filter clamp around the upper and lower filter bodies. Hold the clamp ends to position the clamp on the filter bodies with the clamp ends adjacent to the safety and operation labels on the filter bodies. (Fig 7)
3. Insert clamp bolt through the clamp ends and thread the clamp nut onto clamp bolt with rounded end of the nut (Fig 8) towards the ends of the clamp.
4. Never rely on hand tightening of clamp nut to clamp bolt. Using a 3/4" socket on a torque wrench, torque clamp nut to clamp bolt to 150 inch-lbs. (Fig 9)

⚠ WARNING : DO NOT HIT OR STRIKE CLAMP WITH HAMMER OR METAL TOOLS.

5. Follow Operation Instructions for "Starting the Pump and Filter System" (Page 5).

6. Vacuuming Pool

Vacuuming can be performed directly into the filter whenever needed. Clean cartridges after vacuuming, if required.

7. Manual Air Relief Valve

7.1 Removing the Manual Air Relief Valve

⚠ WARNING

⚠ This product should be installed and serviced only by a qualified pool professional.

Your Filter comes with a Manual Air Relief Valve (MAR) pre-installed from the factory. For Qualified pool professionals only: If MAR valve needs to be serviced, follow these instructions carefully.

1. Turn off all system circulation pumps and all electric power on the equipment pad.
2. Set all system valves in a position to prevent from flowing to the filter.
3. The manual air relief valve must be placed in the OPEN position.
4. Wait until all water leakage has stopped.
5. Grasp the MAR body at the flats, turn the MAR counterclockwise until the indicator on the on the MAR flange is aligned with the "UNLOCK" position on the upper filter body.
6. Pull straight up to remove the MAR, a slight rocking motion may help.

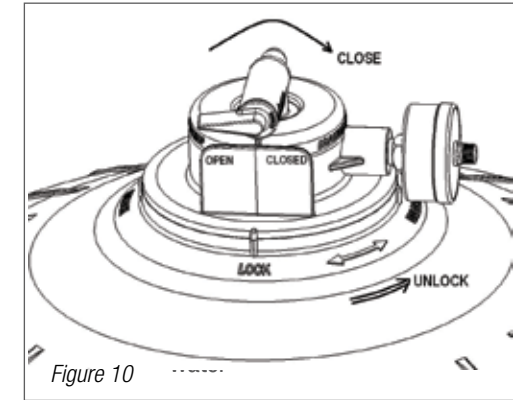

MANUAL AIR RELIEF SHOWN OPEN IN LOCKED POSITON
Rotate counterclockwise to UNLOCK

7.2 Re-Installation of the Manual Air Relief Valve

⚠ This product should be installed and serviced only by a qualified pool professional.

1. Check the o-ring seals, replace as needed.
2. With a clean cloth, wipe upper filter body and o-ring groove. Remove all dirt and debris.
3. Align the notch in the MAR Flange with notch on top of the upper filter body.
4. Press the MAR straight down into the upper filter body.
5. Turn the MAR clockwise until the indicator is aligned with the "LOCK" position on the upper filter body.
6. Verify the MAR discharge points away from all electrical connections.

8. Winterizing Filter

⚠ WARNING

⚠ This product should be installed and serviced only by a qualified pool professional.

⚠ In areas where subfreezing temperatures can be expected, the filter should be drained to protect the filter from damage.

1. The filter should be disassembled and the filter cartridges elements cleaned or replaced.
2. Follow directions under FILTER DISASSEMBLY INSTRUCTIONS
3. Then follow REMOVING CARTRIDGES per instructions
4. Reassemble per FILTER RE-ASSEMBLY INSTRUCTIONS.
5. Be sure to leave the drain plug unattached during the winter season to avoid cracking the filter body.

9. Service and Repairs

Consult your local authorized Hayward dealer or service center. No returns may be made directly to the factory without the expressed written authorization of Hayward Pool Products.

SUGGESTED POOL CHEMISTRY LEVELS

pH	7.2 to 7.8
TOTAL ALKALINITY	80 to 120 ppm
CALCIUM HARDNESS	200 to 400 ppm
COMBINED CHLORINE	.2 ppm Maximum
CHLORINE (STABILIZED)	1.0 to 3.0 ppm
CHLORINE STABILIZER (Cyanuric Acid)	60 to 80 ppm

PROBLEM SOLVING LIST

REMEDY

LOW WATER FLOW

1. Check skimmer and pump strainer baskets for debris.
2. Check for restrictions in intake and discharge lines.
3. Check for air leak in intake line (indicated by bubbles returning to pool).

SHORT FILTER CYCLES

1. Check for algae in pool and super-chlorinate as required.
2. Be sure chlorine and pH levels are in proper range (adjust as required).

POOL WATER WON'T CLEAR UP

1. Check chlorine, pH and total alkalinity levels and adjust as required.
2. Be sure flow rate through filter is sufficient.
3. Operate filter for longer periods.

Head Loss HCF7030C Top Manifold

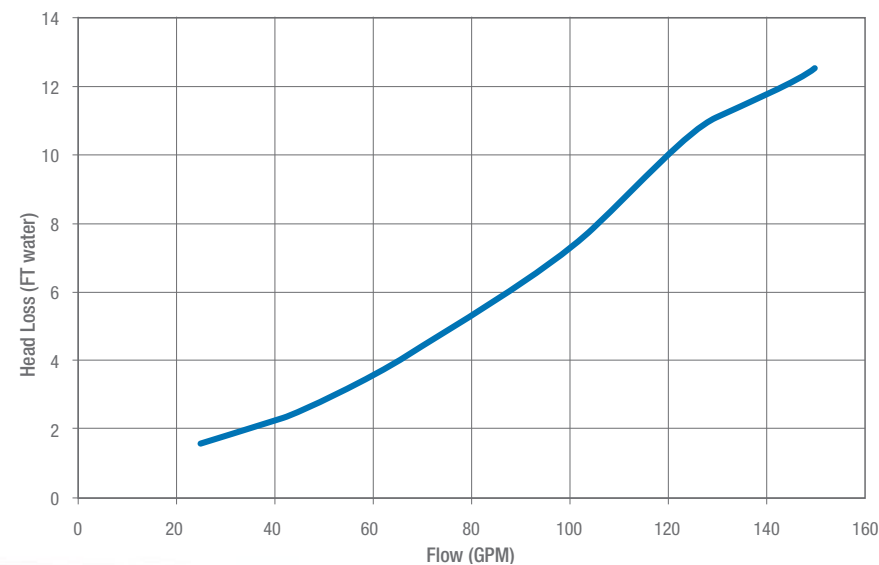

10. Replacement Part Drawing and Numbers

Model HCF7303C		
#	Description	Hayward Part #
1	Pressure Gauge	ECX2712B1
2	O-Ring Kit (Set of 2)	DEX2420Z8A
3	Air Relief Valve Nut	CCX1000N
4	Manual Air Relief w/O-Ring	CX1000V
5	Manual Air Relief Assembly	DE2420MAR2
6	Upper Filter Body HCF7030C	DEX7220B3C
7	Clamp Bolt & Nut	DEX2421J2
8	Clamp System-including: Clamp, Clamp Nut and Bolt, Hang tag, Metal Reinforced Seal, and Labels	DEX2421J.KIT
9	Top Manifold	CX5030C
10	Air Relief Filter	CX3000J1
11	Air Relief Tube	CX2030Z3
12	Cartridge Element C7030 Series 8 Required	CX591XRE
13	Mid plate Connector C7030 only	CX7020M
14	O-Ring	DEX2400Z5
15	Outlet Elbow w/Pipe HCF7030C	CX3030F5
16	Inlet Elbow	CX3020FB
17	Bottom Seal Plate	CX3030D
18	Lower Filter Body	DEX2420A3C
19	1 1/2" Drain Plug w/O-Ring	SP1022C
20	Strap kit (Optional)	DEX2420DCKIT
21	O-ring	SX220Z2
22	Bulkhead Fitting	CX3035F
23	Union Gasket (T-seal)	SPX3200UG
24	Union Connection Kit (includes Nut, Connector, Gasket)	SPX3200UNKIT
25	Label Pack: Includes all Warning and Operation Label's Hang Tag, Wire Tie and Owner's Manual	DEX2420LA6PAK

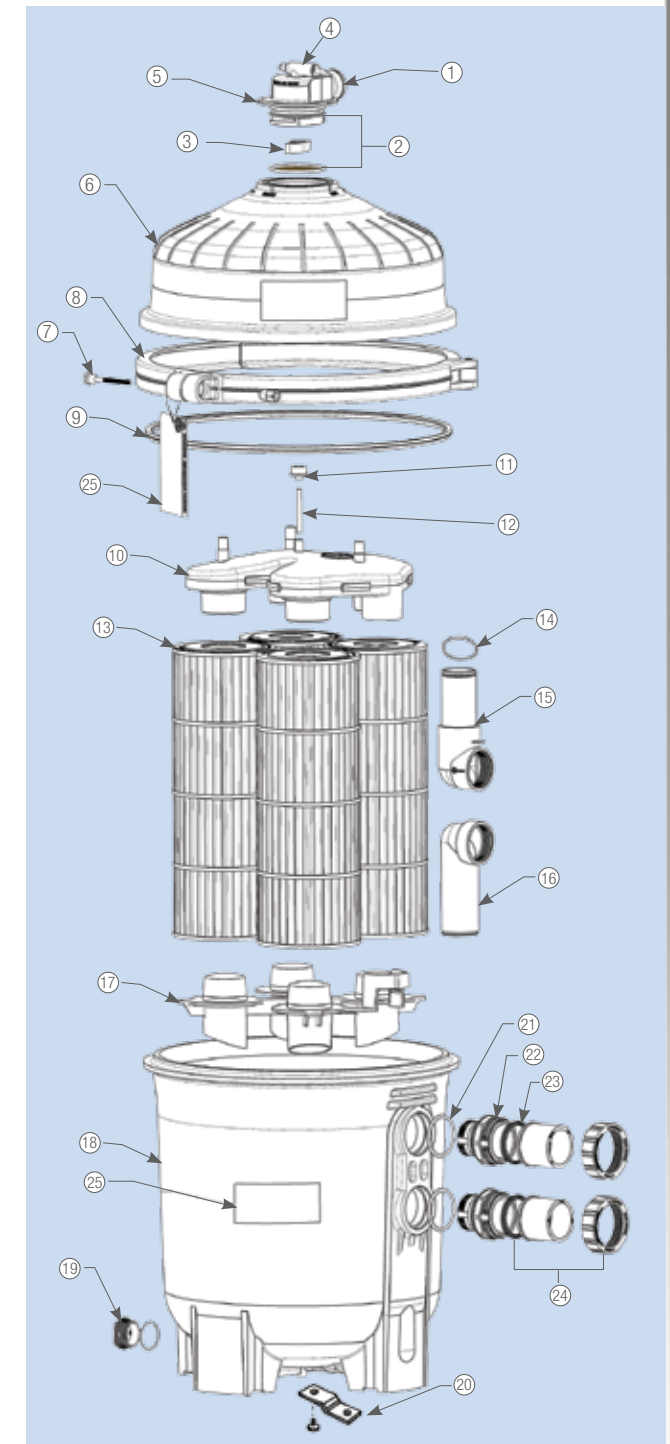

11. Warranty

Hayward® Limited Warranty

To original purchasers of this equipment, Hayward Commercial Pool Products warrants its filters to be free from defects in materials and workmanship for a period of ONE (1) year from the date of purchase.

The limited warranty excludes damage from freezing, negligence, improper installation, improper use or care or any Acts of God. Parts that fail or become defective during the warranty period shall be repaired or replaced, at our option, within 90 days of the receipt of defective product, barring unforeseen delays, without charge.

Proof of purchase is required for warranty service. In the event proof of purchase is not available, the manufacturing date of the product will be the sole determination of the purchase date.

To obtain warranty service, please contact the place of purchase or the nearest Hayward Authorized Service Center. For assistance on your nearest Hayward Authorized Service Center please visit us at www.haywardcommercialpool.com.

Hayward shall not be responsible for cartage, removal, repair or installation labor or any other such costs incurred in obtaining warranty replacements or repair.

The Hayward Commercial Pool Products warranty does not apply to components manufactured by others. For such products, the warranty established by the respective manufacturer will apply.

The express limited warranty above constitutes the entire warranty of Hayward Commercial Pool Products with respect to its' pool products and is in lieu of all other warranties expressed or implied, including warranties of merchantability or fitness for a particular purpose. In no event shall Hayward Commercial Pool Products be responsible for any consequential, special or incidental damages of any nature.

Some states do not allow a limitation on how long an implied warranty lasts, or the exclusion of incidental or consequential damages, so the above limitation may not apply to you. This warranty gives you specific legal rights, and you may also have other rights, which vary from state to state.

Hayward Commercial Pool Products, 10101 Molecular Drive, Suite 200, Rockville, MD 20850

** Supersedes all previous publications.*

12. Product Registration

DATE OF INSTALLATION _____
INITIAL PRESSURE GAUGE READING (CLEAN FILTER) _____
PUMP MODEL _____ HORSEPOWER _____

** Retain this Warranty Certificate in a safe and convenient location for your records.*

13. Warranty Card Registration

DETACH HERE: Fill out bottom portion completely and mail within 10 days of purchase/installation or register online.

Mail to: Hayward Pool Products, 620 Division Street, Elizabeth, NJ 07207; **Attn:** Warranty Dept
Or, register your warranty online at <http://www.haywardcommercialpool.com>

Please Print Clearly:

HCF Cartridge Filter

First Name _____ Last Name _____
 Street Address _____
 City _____ State _____ Zip _____
 Phone Number _____ Purchase Date _____
 E-Mail Address _____
 Serial Number (10-17 digit number) _____
 Model Number _____
 Pool Capacity _____ (U.S. Gallons)
 Please include me on all e-mail communications regarding Hayward® equipment or promotions.

WARRANTY CARD REGISTRATION

Years Pool has been in service: <1 year 1-3 4-5 6-10 11-15 >15
 Purchased from _____
 Builder Retailer Pool Service Internet/Catalog
 Company Name _____
 Address _____
 City _____ State _____ Zip _____
 Phone _____
 Type of Pool: Concrete/Gunite Vinyl Fiberglass Other _____
 New Installation Replacement
 Installation for: In-Ground Above-Ground Spa