



Swim Happy.™

## RESIDENTIAL MANUAL

# Clear Comfort Pool & Inground Spa Sanitation Systems

Patented Hydroxyl-Based Advanced Oxidation (AOP)  
Installation, Operations & Maintenance Manual

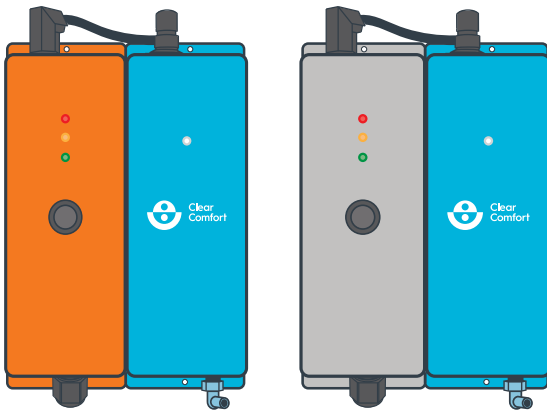

## IMPORTANT SAFETY INSTRUCTIONS



For the latest manual  
version, scan the QR code or visit:  
[clearcomfort.com/residential-manual](https://clearcomfort.com/residential-manual)



# We're here to help

Have questions? For assistance, contact us:

☎ 303.872.4477

✉ [support@clearcomfort.com](mailto:support@clearcomfort.com)

🌐 [clearcomfort.com/help](https://clearcomfort.com/help)

---

For the latest manual  
version, scan the QR code or visit:  
[clearcomfort.com/residential-manual](https://clearcomfort.com/residential-manual)



# TABLE OF CONTENTS



<b>WARRANTY: CCW100 &amp; CCW50 .....</b>	<b>2</b>
How to Activate Your Warranty.....	3
<b>GENERAL INFORMATION .....</b>	<b>4</b>
Important Safety Instructions.....	4
Electrical Safety .....	5
Grounding .....	5
General Safety .....	5
Light Functionality .....	6
Additional Light Functionality Instructions .....	8
<b>STANDARD CLEAR COMFORT SYSTEM DESCRIPTIONS.....</b>	<b>9</b>
Key Features.....	9
Operating Ranges.....	9
Cartridge Connection.....	10
<b>SYSTEM INSTALLATION: POOLS &amp; INGROUND SPAS .....</b>	<b>11</b>
Recommended Materials and Tools .....	11
Electrical Installation - General.....	12
Electrical Installation - Directly to Pump Circuit.....	13
<b>PRE-ASSEMBLED MANIFOLD INJECTION INSTALLATION .....</b>	<b>14</b>
Full System Diagram: Manifold Injection .....	14
Manifold Installation .....	15
Connecting Clear Comfort System to Manifold Venturi .....	17
Operating Instructions .....	19
<b>FULL POOL SYSTEM INTEGRATION DIAGRAMS .....</b>	<b>20</b>
Diagram: Inline Chlorine Feeder .....	20
Diagram: Offline Chlorine Feeder.....	20
Diagram: Salt Water Chlorine Generator .....	21
Diagram: UV System .....	21
<b>BASIC WATER CARE: POOLS &amp; INGROUND SPAS.....</b>	<b>22</b>
<b>SYSTEM MAINTENANCE: CARTRIDGE EXCHANGE .....</b>	<b>23</b>
How to Exchange Your Cartridge: CCW100 & CCW50 .....	23
How to Replace Your Air Check Valve.....	25
How to Install Your Valved Flowmeter Kit.....	25
<b>FREQUENTLY ASKED QUESTIONS.....</b>	<b>26</b>

**WARRANTY: CCW100 & CCW50**

Clear Comfort warrants all Equipment to be free from defects in material or workmanship under normal use and service. Clear Comfort, Inc. at its discretion may repair or replace the Equipment or parts thereof. The Company's warranty does not cover any Equipment that has been altered or changed in any way by any person not authorized by Clear Comfort, INC.

THIS CONSTITUTES THE SOLE WARRANTY MADE BY CLEAR COMFORT, INC. EITHER EXPRESSED OR IMPLIED. THERE ARE NO OTHER WARRANTIES EXPRESSED OR IMPLIED WHICH EXTEND BEYOND THE FACE HEREOF, INCLUDING THE IMPLIED WARRANTIES OF MERCHANTABILITY AND FITNESS FOR A PARTICULAR PURPOSE. IN NO EVENT WILL CLEAR COMFORT, INC. BE LIABLE FOR ANY INCIDENTAL OR CONSEQUENTIAL DAMAGES AND CUSTOMER'S REMEDIES ARE LIMITED TO REPAIR OR REPLACEMENT OF NONCONFORMING CLEAR COMFORT Systems OR PARTS.

This equipment was inspected before shipment from our plant. To original purchasers of this equipment, Clear Comfort Water Inc. ("Clear Comfort"), warrants its Clear Comfort Systems to be free from defects in materials and workmanship for a period of FIVE (5) years from the date of purchase. Replacement Cartridges and cylinders are warranted for a period of ONE (1) year from the date of purchase.

Parts which fail or become defective during the warranty period, except as a result of freezing, negligence, improper installation, use, or care, shall be repaired or replaced, at our option, without charge, within 90 days of the receipt of defective product, barring unforeseen delays.

To obtain warranty replacements or repair, defective components or parts should be returned, transportation paid, to the place of purchase, or to the nearest authorized Clear Comfort service center. For further Clear Comfort dealer or service center information, contact Clear Comfort customer service department.

Clear Comfort shall not be responsible for Cartridge, removal and/or re-installation labor or any other such costs incurred in obtaining warranty replacements.

The Clear Comfort Products warranty does not apply to components manufactured

by others. For such products, the warranty established by the respective manufacturer will apply.

This warranty shall be voided if at any time: (i) Customer attempts to make any internal changes to any of the components of the Equipment; (ii) the power supplied to any part of the Equipment exceeds the Equipment's operating parameters; (iii) any external device attached by Customer creates conditions exceeding the Equipment's operating parameters; (iv) the Equipment is tampered with; or (v) the serial number is covered, removed or defaced. Clear Comfort, Inc. reserves the right to seek damages if its system is tampered with, reverse engineered, or if Customer takes any other actions to interfere with the operation or integrity of the Clear Comfort system.

**No Other Warranties**

To the maximum extent permitted by applicable law, Clear Comfort disclaims all other warranties, either expressed or implied, including, but not limited to, implied warranties of merchantability and fitness for a particular purpose, with regard to the product(s), part(s) and/or any accompanying written materials.

**Procedure for Obtaining Performance**

In order to obtain the benefits of this warranty, the customer who made the original retail purchase must contact the Clear Comfort Technical Service Department as soon as possible after discovery of the product-related issue, but in no event later than the expiration date of the respective warranty periods provided herein. Upon receipt of this communication, Clear Comfort will promptly notify the customer of the address to which the product may be shipped. The customer shall then ship the product, freight prepaid, to the address indicated, together with a "RETURN GOODS AUTHORIZATION" form obtained from Technical Service and a brief description of the problems encountered. Unauthorized returns will not be accepted. Freight must be prepaid by customer.

**Warranties or Representations by Others**

No third party has any authority to make any warranties or representation concerning Clear Comfort or its products. Accordingly, Clear Comfort is not responsible for any such warranties or representations.

## HOW TO ACTIVATE YOUR WARRANTY

You must activate and validate your warranty within 1 year of your ship date from Clear Comfort either by submitting your warranty card to the address below or by filling out our warranty form online.

### Option 1: Mail Your Warranty Card

Address your warranty card to:

Clear Comfort  
168 CTC Blvd, Suite E  
Louisville, CO 80027  
303.872.4477

[support@clearcomfort.com](mailto:support@clearcomfort.com)



### Option 2: Submit Your warranty online

Fill out our warranty form at:

[clearcomfort.com/warranty](https://clearcomfort.com/warranty)



## GENERAL INFORMATION

## IMPORTANT SAFETY INSTRUCTIONS

**1. READ AND FOLLOW ALL INSTRUCTIONS.**

**2. For cord connected/convertible units:** DANGER – Risk of injury.

**A.** Replace damaged cord immediately.

**B.** Do not bury cord.

**C.** Connect to a grounding type receptacle only.

**3. For all permanently connected units intended for use on 15 or 20 ampere, 125V or 230V, single phase branch circuits:** WARNING – Risk of Electric Shock. Connect only to a branch circuit protected by a ground-fault circuit-interrupter (GFCI). Contact a qualified electrician if you cannot verify that the circuit is protected by a GFCI.

**4. For all cord connected units other than storable pool pumps:** WARNING – Risk of Electric Shock. Connect only to a grounding type receptacle protected by a ground-fault circuit interrupter (GFCI). Contact a qualified electrician if you cannot verify that the receptacle is protected by a GFCI.

**5. For all permanently connected units:** WARNING – Risk of Electric Shock. Connect only to a branch circuit protected by a ground-fault circuit-interrupter (GFCI). Contact a qualified electrician if you cannot verify that the receptacle is protected by a GFCI.

**6. For units intended for above-ground storable swimming pools:** Do not bury cord. Locate cord to minimize abuse from lawn mowers, hedge trimmers, and other equipment.

**7. For all cord and plug connected units:** WARNING – To reduce the risk of electric shock, replace damaged cord immediately.

**8. For units intended for above ground storable swimming pools:**

WARNING – To reduce the risk of electric shock, do not use extension cord to connect unit to electric supply; provide a properly located outlet.

**9. CAUTION:** At low or no flow conditions, gas may accumulate – ensure system is off when backwashing or when water is not being treated to prevent an unsafe gas buildup. Pressure switches, flow switches and other safety equipment to prevent unsafe gas buildup is recommended.

**10. When the modified air is introduced into the pool or spa water via the existing plumbing,** the biocide is produced. Some of the remaining activated atoms either keep minerals dissolved in the water or remove minerals that were previously deposited.

**11. This unit is to be installed in accordance with the installation instructions,** the applicable plumbing and building codes, the applicable state and local laws and regulations, and the requirements of the Authority Having Jurisdiction.

**12. When installing and using this equipment,** basic safety precautions should always be followed including the following.

**13. WARNING -** To reduce the risk of injury, do not permit children to use this product unless they are closely supervised at all times.

**14. WARNING -** Do not sit or stand on unit.

**15. SAVE THESE INSTRUCTIONS.**

## ELECTRICAL SAFETY

- Do not service the machine when the power is ON.
- The power supply wire gauge and insulation must meet the temperature and power requirements.
- To avoid personal injury never touch exposed electrical connections or components while the power is ON.
- Do not install/service the Clear Comfort system if you or the machine is standing in water with the power ON.
- Protect the power cord from being walked on or pinched, particularly at plugs and the point where they exit from the system.
- The device must be properly connected to the correct power source (either 60Hz 120V or 230V) using the supplied power cord in accordance with the local electrical code. If possible the unit should be hardwired to the pump circuit and controlled by the pump circuit (rather than hardwiring, an appropriate 120V or 230V receptacle outlet and plug may be used to connect to

the pump controlled circuit). If the unit is being wired to standalone AC power (i.e., not through the pump circuit on either 120V or 230V) it should be installed with its own timer circuit and plugged in through a Ground Fault Circuit Interrupt (GFCI) and the timer should be set to reflect the pool or tub's hours of operation. Regardless if hardwired or standalone connected, the electrical connection must be made in accordance with the local electrical code.

## GROUNDING

The Clear Comfort, Inc. system must be properly grounded. An electrical ground connection to a reliable earth ground is essential for safe operation. Without an electrical ground, all accessible conductive components (including knobs and controls that appear insulated) can render an electrical shock.

## GENERAL SAFETY

Use personal protective equipment (steel toe shoes, hearing protection, eye protection) when installing the Clear Comfort system. Follow ladder safety requirements.



## FRONT VIEW: CCW100 MEDIUM TO LARGE POOL SYSTEM



Figure 1: CCW100 System Functions

## LIGHT FUNCTIONALITY

**Green LED Light:** System is on and operating properly.

**Yellow LED Light:** Cartridge Unit has reached 80 percent of its life expectancy (8,000 hours) and it's time to purchase a replacement cartridge.

To exchange your Cartridge Unit, please visit: [clearcomfort.com/cartridge](http://clearcomfort.com/cartridge)

**Red LED Light:** Cartridge Unit has reached its life expectancy and needs to be replaced.

**Blue Light:** Operation light that should always be illuminated.



## FRONT VIEW: CCW50 SMALL POOL &amp; INGROUND SPA SYSTEM

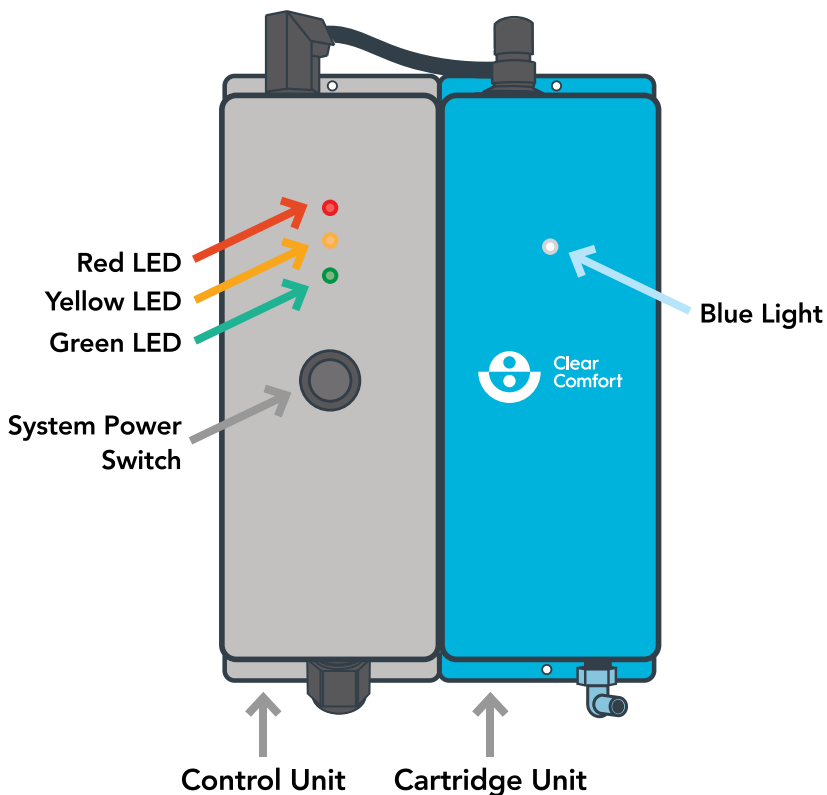

Figure 2: CCW50 System Functions

## LIGHT FUNCTIONALITY

**Green LED Light:** System is on and operating properly.

**Yellow LED Light:** Cartridge Unit has reached 80 percent of its life expectancy (8,000 hours) and it's time to purchase a replacement cartridge.

To exchange your Cartridge Unit, please visit: [clearcomfort.com/cartridge](http://clearcomfort.com/cartridge)

**Red LED Light:** Cartridge Unit has reached its life expectancy and needs to be replaced.

**Blue Light:** Operation light that should always be illuminated.

## LIGHT FUNCTIONALITY

**Please Note:** When powering on the system, the Cartridge Unit's Blue Light will turn on first. Then, the Control Unit cycles twice between green, yellow, red and finally settles on green.

## ADDITIONAL LIGHT FUNCTIONALITY INSTRUCTIONS

**Green Light:** Cartridge life is between 0 - 7,999 hours (good, no action needed).

**Green & Yellow Light:** Cartridge life is reaching 8,000 - 9,999 hours (order your Cartridge exchange).

To exchange your Cartridge Unit, please visit: [clearcomfort.com/cartridge](https://clearcomfort.com/cartridge)

**Red Light:** Cartridge life has exceeded 10,000 hours (immediately exchange your Cartridge).

**Flashing Red & NO Blue Light:** The Cartridge is not being sensed by the Control Unit. See page 10 for more information.

## STANDARD CLEAR COMFORT SYSTEM DESCRIPTIONS

### KEY FEATURES

This manual describes how to install, operate and maintain the standard Clear Comfort system. Installing your Clear Comfort system is a simple process that can be performed by any professional. This process can be performed in 1 hour or less on most pools. After the Clear Comfort system is installed, it is ready to start treating the water immediately. The Clear Comfort system protects pool or spa water (biocide, scale control and corrosion control) without the harsh effects of salt, chlorine, high cyanuric acid or high chlorine levels. The only system maintenance required with a Clear Comfort system is an annual 5-minute cartridge exchange and industry-standard weekly chemical balancing.

### OPERATING RANGES

Power: 120V or 230V receptacle with approximately 10 watts.

Ballast: 120V or 230V

**Electrical Requirements: 120V, 60Hz**

**Electrical Rating: 120V, 60Hz, 1.0Amp or 230V, 60Hz, 0.5Amp**

**NOTE: CLEAR COMFORT SHOULD ONLY RUN WHEN THE PUMP IS OPERATING**

## CARTRIDGE CONNECTION

Gently align the notched outdent on the front of the Cable Connector with the keyed indent on the front of the Cartridge Connector, as shown with the arrow in Figure 3. Seat the Cable Connector down onto the Cartridge Connector and turn the Cable Connector's Collar a quarter-turn clockwise to lock the Cable and Cartridge Connector together.

If strange indicator light pattern occurs, turn OFF the Control Unit, disconnect the Cable Connector, allow 5 minutes for the ballast reset, reconnect the Cable Connector, and turn the Control Unit ON.

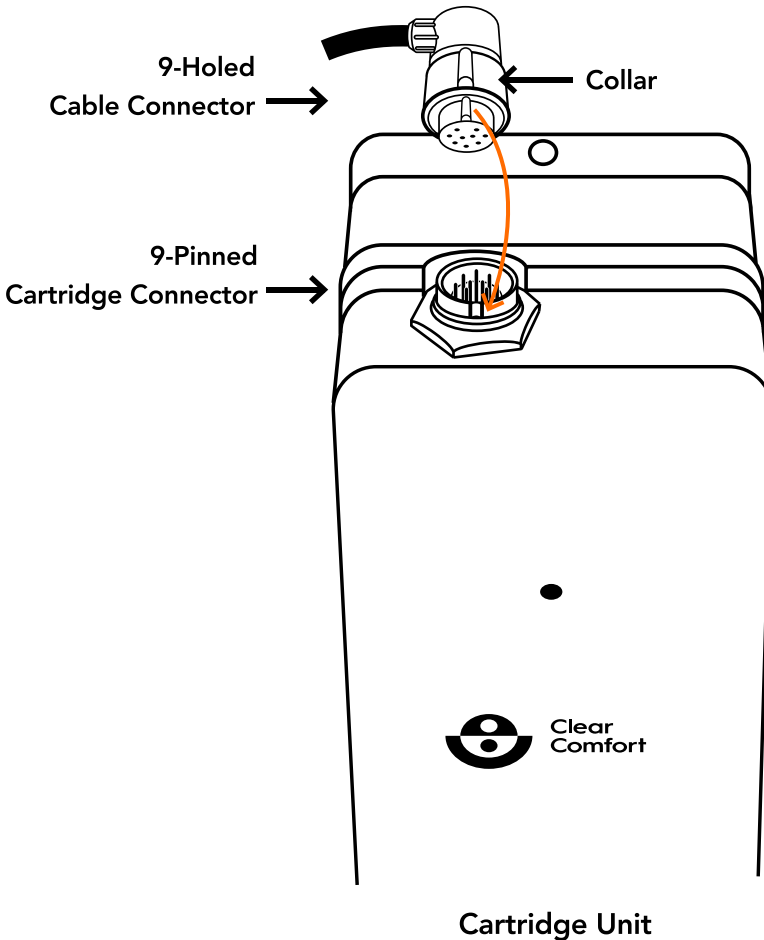

Figure 3: Cartridge Connection

## SYSTEM INSTALLATION: POOLS & INGROUND SPAS

### *For the CCW100 Pool System or CCW50 Inground Spa & Small Pool System*

Prior to installation, a site survey should be performed to validate that the correct system parameters are in place and ready for installation. We recommend that you maintain compliance within the following operating ranges for well constructed and circulated pools.

- **Maximum flow rate treated:**
  - **CCW100:** 90 GPM
  - **CCW50:** 35 GPM
- **Type of pool/spa filter:** Any ANSI 50 approved filtration.
- **Type of pump:** Variable speed pump is highly recommended.
- **Voltage of power supply:** 120V or 230V AC.
- **Maximum distance from injection point:** Air Tubing length should be as short as possible with no more than 10 feet from the system to the Manifold/Venturi injection location.
- **Indoors or outdoors:** Either is suitable. It is recommended to install away from upward facing sprinklers.
- **Water quality at installation:** The water quality should be balanced prior to installing the Clear Comfort system.

### EQUIPMENT LIST: CCW100 OR CCW50

- Manifold
- 10' Air Tubing With Air Check Valve
- Valved Flow Meter Kit
- Conduit Connector
- Conduit Box and Lid
- 12" Conduit Tubing

### RECOMMENDED MATERIALS AND TOOLS

- A power drill and proper hardware for mounting the Clear Comfort system.
- Proper plumbing materials and tools for Manifold injection installation.
- Proper electrical materials for outdoor, high voltage electrical connection.

## SYSTEM INSTALLATION: POOLS & INGROUND SPAS

1. Determine the best location to mount the Clear Comfort system. Screw in the top mounting bracket first, and then the bottom mounting bracket of the Control Unit (orange or silver unit). Mount the Cartridge Unit (blue unit) by securely fastening the Cartridge Unit to the Control Unit using side keyed brackets, and screw in the top mounting bracket first, and then the bottom mounting bracket.
2. System must be installed no more than 10 feet from the Manifold/Venturi injection location.
3. Where possible, ensure system location is at least one (1) foot above the water line of pool/spa and Manifold/Venturi injection site.

## ELECTRICAL INSTALLATION - GENERAL

1. Follow all local and national electric codes.
2. Determine your system's version:
  - V2.1 With Ballast Switch: If your system has a 120V and 230V ballast switch, continue to Step 5 and/or scan QR code for voltage setting tutorial.
  - V2.2 No Ballast Switch: If your system doesn't have a ballast switch, your system is auto-ranging and can be wired for either 120V or 230V, skip to Step 5.
3. Determine if your system will be powered by 120V or 230V.  
**NOTE:** V2.1 CCW100 and CCW50 systems are factory set to 230V. If your system will be powered by 230V, skip to Step 5.
4. Set the ballast switch on V2.1 Control Unit: Remove plug in the left side of the Control Unit. With a small screwdriver, slide the switch down into the 120V position, according to the Control Unit label. Re-install the plug. See Figure 4.
5. The Clear Comfort system comes with a 12-inch section of 1/2 inch flexible conduit, a water-tight conduit fittings, and a water-tight single-gang junction box.

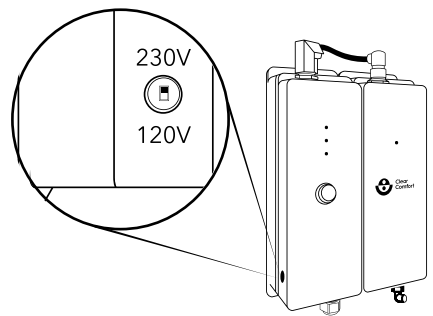

Figure 4: Ballast Electrical Switch

6. If 12 inches is too long, cut to the desired length. Slide the wires from the Clear Comfort system through the conduit, insert the conduit into the water tight connector on the Clear Comfort system, and tighten down.
7. Position the junction box as needed for the installation and attach the water tight conduit fitting to the junction box.
8. Slide the conduit and wire into the junction box and tighten down the water-tight connection.
9. Run wire (and conduit, if required by local code) from the pump circuit to the junction box using water-tight fittings.
10. Using appropriately sized wire nuts inside the junction box, connect the switched power to the Clear Comfort system.

**NOTE: CLEAR COMFORT SHOULD ONLY RUN WHEN THE PUMP IS OPERATING**

### **ELECTRICAL INSTALLATION - DIRECTLY TO PUMP CIRCUIT (RECOMMENDED)**

1. Direct pump circuit connection is recommended. Unit should be hardwired to the pump circuit and controlled by the pump circuit.
2. Timer Controlled Pumps: Wire to the load side of the timer.
3. Breaker or Switch Controlled Pumps: Wire to the load side of the breaker or switch.
4. Pool Controllers: Wire to terminals labeled Load - Pump. Always confirm voltage and switching with a reliable volt meter. All wiring must be in accordance with the NEC and local regulations.
5. Test for proper grounding and secure connections.

**NOTE: WIRE THE SYSTEM TO RUN ONLY WHEN THE PUMP IS RUNNING**

## PRE-ASSEMBLED MANIFOLD INJECTION INSTALLATION

## FULL SYSTEM DIAGRAM: MANIFOLD INJECTION

**NOTE:** The Manifold injection is the preferred Clear Comfort pool and inground spa system installation method.

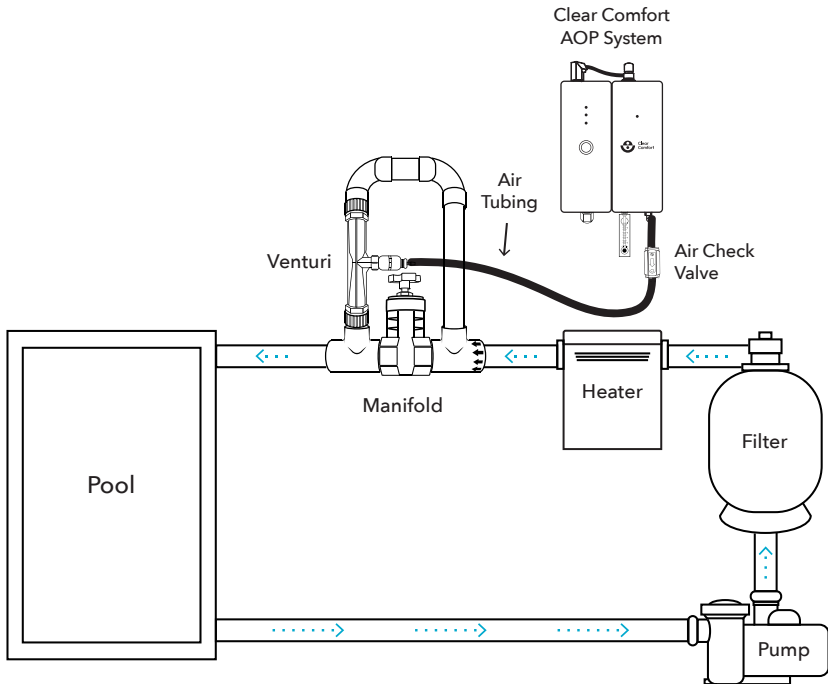

**Figure 5: Full System Diagram With Manifold Injection**

**NOTE:** For full system diagrams that include additional sanitation systems integrated with the Clear Comfort system, see page 20 and 21.

For other install diagrams and instructions, please visit: [clearcomfort.com/help](https://clearcomfort.com/help)



## MANIFOLD INSTALLATION (PREFERRED METHOD)

*PLEASE NOTE: Turn main pool pump OFF and switch off main circuit breaker.*

### • Step 1: Pick Location

- Select a location to install Manifold, see Step 2 for proper water flow configuration position.
- If retrofitting, cut a 11" length of the main return piping where the bypass will be installed.

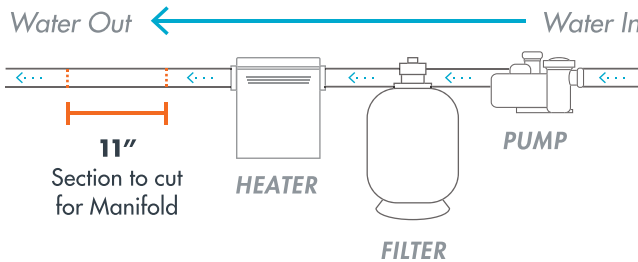

Figure 6: Manifold Location

### • Step 2: Select Orientation

- The Gate Valve Manifold can be installed either left-to-right or right-to-left to match your water flow configurations.

Simply align the Gate Valve Manifold’s directional flow arrows with the direction of water flow.

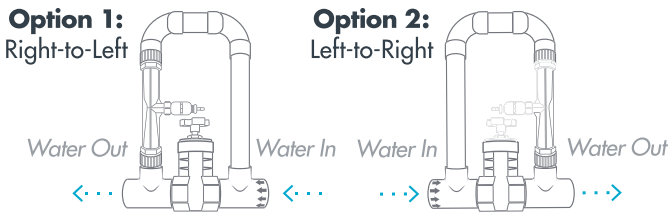

Figure 7: Manifold Orientation

**Step 3: Connect to Pool Plumbing**

- Install the Gate Valve Manifold into the 11” cut section of pool plumbing, using an appropriate PVC primer and cement.

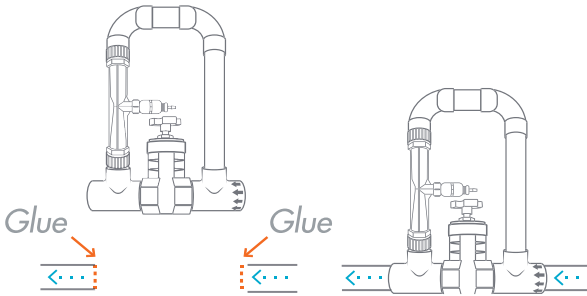

Figure 8: Connecting Manifold

**Step 4: Connect to System & Set Gate Valve Air Flow**

- Connect blue Air Tubing from the Clear Comfort System’s L-barbed connector to the Manifold’s Venturi. **IMPORTANT:** The Air Tubing Air Check Valve’s arrow should point away from the Clear Comfort system and to Manifold’s Venturi.
- Install the Valved Flowmeter Kit. See page 25 for instructions.
- Turn on circulation pump and adjust the Gate Valve Manifold’s knob until the Flowmeter meets the required flow rate\*.
- If needed, use the Flowmeter’s knob for fine tuning.



\* The required flow rate for the CCW100 is 5-7 LPM and the CCW50 is 3-5 LPM

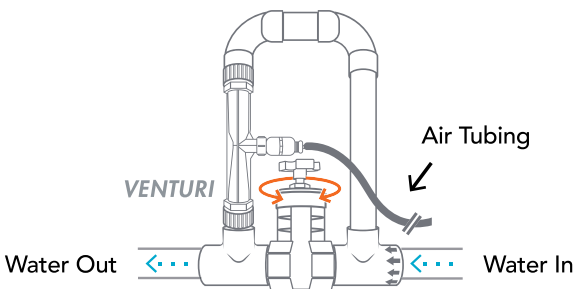

Figure 9: Adjusting Manifold

## CONNECTING CLEAR COMFORT SYSTEM TO MANIFOLD VENTURI

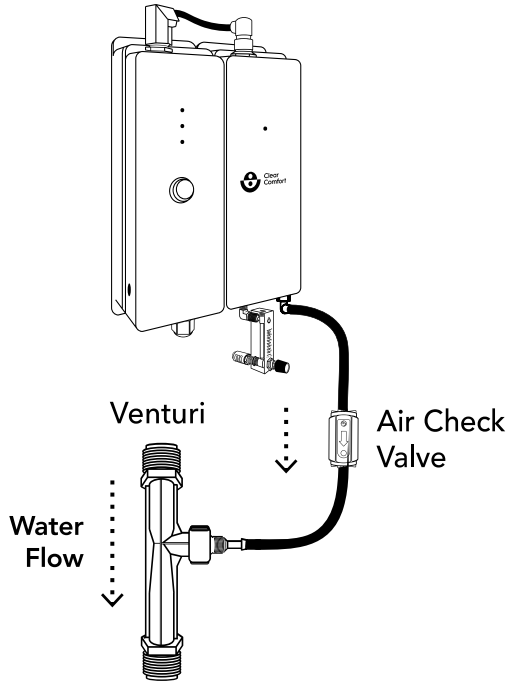

Figure 10: Venturi Connection

From Clear Comfort System

To Venturi

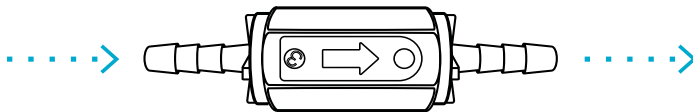

Figure 11: One-Way Air Check Valve

## CONNECTING CLEAR COMFORT SYSTEM TO MANIFOLD VENTURI

1. Run provided 1/4-inch tubing from the Manifold injection port to the straight barb fitting. Length of tube should be less than 10 feet. Shorten and cut tubing as possible. See Figure 10.
2. Install 1/4-inch one-way Air Check Valve (supplied) to prevent any potential water back flow. See Figure 10 and Figure 11 for details.

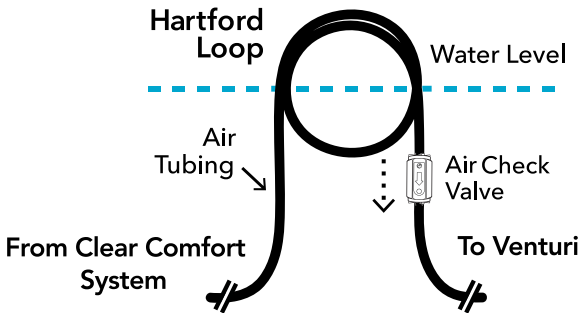

Figure 12: Hartford Loop





3. If the Control and Cartridge Units are installed below the water line, install a Hartford loop in the 1/4-inch tubing, and wherever possible position the Hartford loop above the water line.
4. Where it is not possible to position the Hartford loop above the water line, **install a water check valve** in the return line downstream of the Manifold.
5. Measure air suction using an Air Flow Meter and set Venturi air suction to draw within the required air flow rate ranges:
  - CCW100: 5 - 7 LPM
  - CCW50: 3 - 5 LPM

See page 16 for detailed instructions.

## OPERATING INSTRUCTIONS

1. Install plumbing according to Figure 5.
2. Ensure the Manifold is in the proper position before turning on pump. See Figure 7.
3. Turn pool/spa pump and filtration systems on.
4. Connect the Manifold and set air flow. See page 16 for instructions. Adjust the Gate Valve Manifold's knob until the Flowmeter meets the required flow rate:
  - CCW100: 5 - 7 LPM
  - CCW50: 3 - 5 LPM
5. Toggle Clear Comfort system switch to the upward ON position.
6. Water entering the pool/spa should have bubbles exiting from at least one of the returns on to the body of water.

## SIMPLE SUCCESS SUMMARY

-  Install system with clean pool water
-  Operate your pool with a clean & clear filter
-  Remember to balance the water
-  Adjust air injection to meet required flow rate:
  - CCW100: 5 - 7 LPM
  - CCW50: 3 - 5 LPM
-  Clean, vacuum & brush pool surfaces as needed

### FULL POOL SYSTEM INTEGRATION DIAGRAMS DIAGRAM: INLINE CHLORINE FEEDER

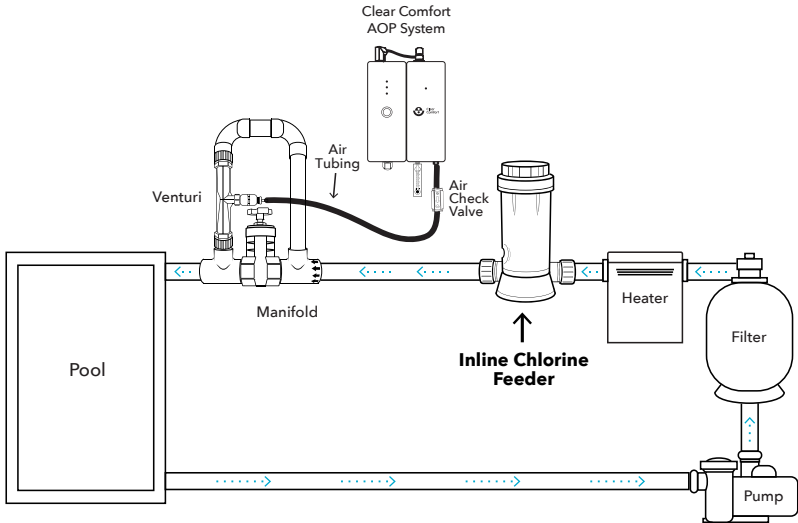

Figure 13: Inline Chlorine Feeder

### DIAGRAM: OFFLINE CHLORINE FEEDER

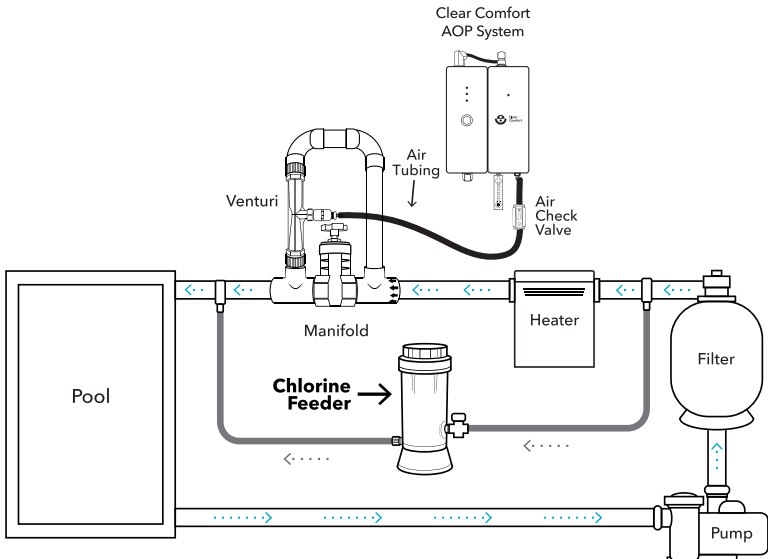
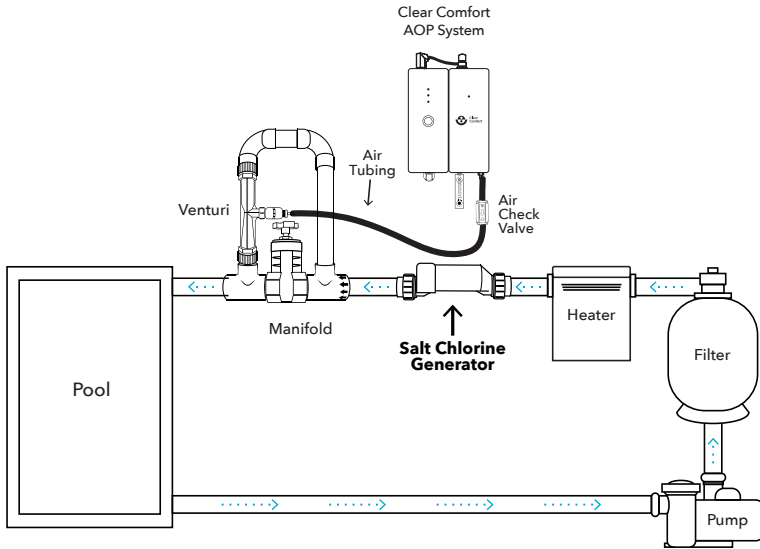

Figure 14: Offline Chlorine Feeder

**DIAGRAM: SALT WATER CHLORINE GENERATOR**



**Figure 15: Salt Water Chlorine Generator**

**DIAGRAM: UV SYSTEM**

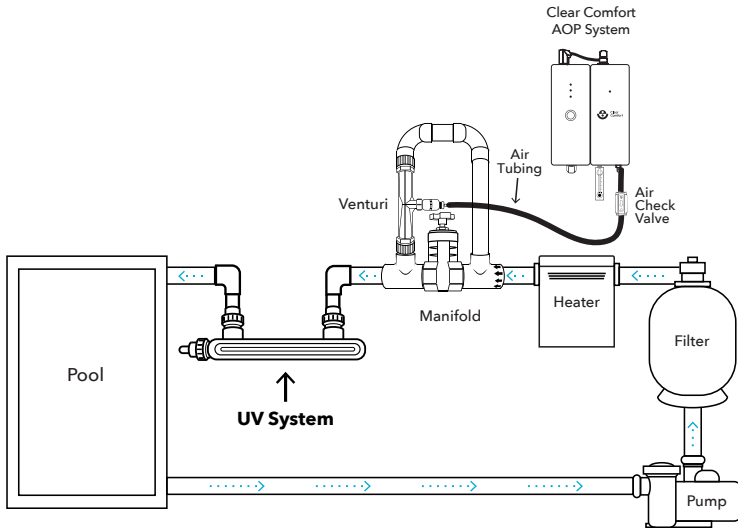
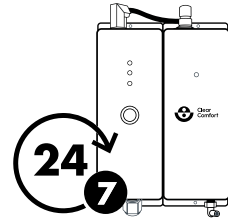

**Figure 16: UV System**

**BASIC WATER CARE: POOLS & INGROUND SPAS**

**1. Run Clear Comfort 24/7:**

- We recommend setting the air injection using a variable speed pool pump that's set between 2200 - 2400 RPM
- If you're using a DE Filter, let it rest for 1 hour everyday



**2. Balance Water**

pH	7.2 - 7.4
Alkalinity	60 - 120 ppm
Cyanuric Acid	20 - 40 ppm
Calcium Hardness	200 - 400 ppm
Total Dissolved Solids (TDS)	Less Than 1,500 ppm
Residual Chlorine	0.5 - 1.5 ppm

**3. Chlorine Options**

	Manual Dosing	Automated Dosing
Cal Hypo (Calcium Hypochlorite)	Non-Stabilized Chlorine Tablets (poolife® NST®)	Tablet Feeder (CCH® Endurance or Other)
Liquid Chlorine (Sodium Hypochlorite)	Liquid Manual Dosing	Automated With Peristaltic Pump & ORP Sensor

**4. Shock As Needed**

- Option 1: Cal-Hypo granules
- Option 2: Liquid chlorine
- Option 3: Non-chlorine shock (not recommended for algae)

**5. Algae Control**

- Use a proactive algae treatment
  - Chelated Copper/Mineral Options:
    - poolife® AlgaeBan II
    - poolife® Algaecide 90
    - POOL Breeze® Opticide®
    - Pool RX
    - SeaKlear 90 Day Algaecide
  - Polyquat Options:
    - poolife® Defend+®
    - GLB® Algimycin® 2000
    - POOL Breeze® Defender



## SYSTEM MAINTENANCE: CARTRIDGE EXCHANGE

### HOW TO EXCHANGE YOUR CARTRIDGE: CCW100 & CCW50



To keep the Clear Comfort system working its best, the Cartridge Unit must be exchanged annually. No other system maintenance is required.

If the **Yellow LED Light** is ON, your Cartridge will expire soon and it's time to order a new replacement Cartridge. **NOTE:** Your new Cartridge includes a shipping label and packaging to return your old Cartridge to Clear Comfort for proper recycling.

**IMPORTANT NOTE:** If the **Red LED Light** is ON, your Cartridge has expired & must be exchanged immediately to protect your water.

To start your exchange and order your new Cartridge replacement, please visit: [clearcomfort.com/cartridge](https://clearcomfort.com/cartridge)



**IMPORTANT NOTE:** For proper recycling, please return your old Cartridge with the provided label and packaging.

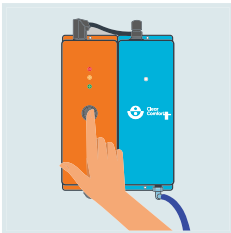

1. Turn off and disconnect power to Clear Comfort system.

**NOTE:** Never attempt to service unit while it is wet. Ensure all LEDs on system front are OFF.

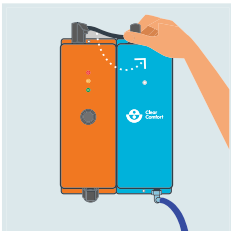

2. To disconnect Cartridge Unit from Control Unit, rotate the cable base on top of the blue Cartridge Unit a quarter turn and gently pull up.

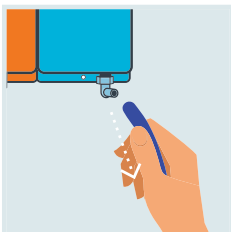

3. Remove the Air Tubing from bottom of Cartridge Unit.



4. Push the old blue Cartridge Unit up and separate it from the Control Unit.

**IMPORTANT:** Save and use the return label and packaging provided with your new Cartridge Unit to send your old Cartridge to Clear Comfort for proper recycling.



5. To attach the new Cartridge Unit, align the side keyed brackets and push down.

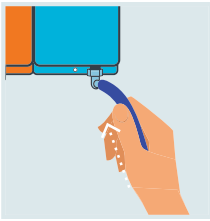

6. Reconnect the Air Tubing to bottom of the Cartridge Unit.

7. Remove old Air Check Valve from Air Tubing and replace with the new Air Check Valve. See page 25 for detailed instructions.



8. Align the Control Unit's cable base slot to the Cartridge Unit's top connector slot, gently push down and rotate a quarter turn. See Figure 3 for details. Reconnect the system's power and turn it on.

**NOTE:** For proper light functionality, please see page 8. If strange light pattern occurs, follow the instructions on page 10.



9. For sustainability purposes, return your old Cartridge with the shipping label and packaging that was provided with your new replacement Cartridge.



## HOW TO REPLACE YOUR AIR CHECK VALVE

### 1. **IMPORTANT! Identify Direction:**

Your Air Check Valve's arrow must point away from your system and to the Venturi.

2. Remove the old Air Check Valve from the Air Tubing.
3. Connect the new Air Check Valve with the arrow pointing to the Venturi's connected Air Tubing. See Figure 10.
4. Connect the other end of the new Air Check Valve with the arrow pointing away from the Clear Comfort System's connected Air Tubing.
5. Again, ensure your new Air Check Valve's arrow is pointing away from the Clear Comfort System and to the Venturi.



## HOW TO INSTALL YOUR VALVED FLOWMETER KIT

### 1. **Install Steel Elbow Fitting**

Screw the Stainless Steel Elbow Fitting into the bottom hole on the Cartridge Unit. Make sure the Elbow Fitting's outlet points forward.

### 2. **Temporarily Uninstall Bottom Fitting**

To make room for the installation, temporarily unscrew and remove the Flowmeter's bottom fitting using a wrench on the threading's flat faces.

### 3. **Install Top Fitting**

Thread the Flowmeter's top fitting onto the Elbow Fitting, do not over tighten.

### 4. **Reinstall Bottom Fitting**

Thread the bottom fitting back into the Flowmeter.

### 5. **Install Air Filter**

Thread the Air Filter into the Flowmeter's bottom fitting.



## FREQUENTLY ASKED QUESTIONS

- **How is the Clear Comfort AOP system different from traditional water sanitation methods?**

The Clear Comfort system uses a patented Hydroxyl-Based AOP (Advanced Oxidation Process) to create hydroxyl radicals, the most powerful oxidative compounds available for recreational water treatment. Clear Comfort protects pool or spa water (biocide, scale control and corrosion control) without the harsh effects of salt, chlorine, high cyanuric acid or high chlorine levels.

- **How does the Clear Comfort AOP system work?**

Using a unique, proprietary and patented AOP technology, the Clear Comfort system treats ambient air and injects it in the pool or spa plumbing to create high concentrations of hydroxyl radicals. These highly-reactive and short-lived hydroxyl radicals rapidly destroy unwanted contaminants, microorganisms, bacteria, protozoa and viruses, while controlling organic material.

- **How long does it take to install the Clear Comfort AOP system?**

Installing your Clear Comfort system is a simple process that can be performed by any professional. This process can be performed in 1 hour or less on most pools. As soon as it is installed, it is ready to start treating the water immediately.

- **Where is the Clear Comfort AOP system installed?**

The Clear Comfort system needs to be within 10 feet of the pool or spa Manifold/Venturi injection site. It can be installed outdoors or indoors. The system's Manifold is installed directly into the pool or spa plumbing, see page 14 for details.

- **Does temperature affect the Clear Comfort AOP system?  
Hot or cold?**

No, the Clear Comfort system is weatherproof for outdoor conditions and can be used in a variety of different climates.

- **How do I know the Clear Comfort AOP system is working?**

When Clear Comfort system is ON and operating properly, both the Control Unit's **Green LED Light** and Cartridge Unit's **Blue Light** should be illuminated.

For proper light functionality, please see page 8. If strange light pattern occurs, follow the instructions on page 10.





# We're here to help

Have questions? For assistance, contact us:

☎ 303.872.4477

✉ [support@clearcomfort.com](mailto:support@clearcomfort.com)

🌐 [clearcomfort.com/help](https://clearcomfort.com/help)

---

For the latest manual  
version, scan the QR code or visit:  
[clearcomfort.com/residential-manual](https://clearcomfort.com/residential-manual)

