



anovafurnishings.com
888.535.5005 tel

ASSEMBLY INSTRUCTIONS

Contour Benches, Portable/Surface Mounted

- D1026** – Ultra 4’ Contour Bench, Perforated Steel
- D1027** – Ultra 6’ Contour Bench, Perforated Steel
- D1027COM** – Ultra 6’ Contour Commemorative Bench, Perforated Steel
- D6003** – Rally 4’ Contour Bench, Perforated Steel
- D6002** – Rally 6’ Contour Bench, Perforated Steel
- D6002COM** – Rally 6’ Contour Commemorative Bench, Perforated Steel
- F1026** – Ultra 4’ Contour Bench, Expanded Steel
- F1027** – Ultra 6’ Contour Bench, Expanded Steel
- L1343** – Ultra 4’ Contour Bench, Slotted Steel
- L1337** – Ultra 6’ Contour Bench, Slotted Steel
- C1337** – Ultra 6’ Custom Contour Bench, Slotted Steel
- C1337BB** – 6’ Contour Buddy Bench, Slotted Steel



D1027

TOOLS NEEDED:

- 3/4" Open-end or Box-end Wrench
- Ratchet with 3/4" Socket
- Level

ASSEMBLY HARDWARE:



4 x
1/2-13 X 1.5"
Hex Head Bolt



4 x
1.375" OD x .109 THK
Washer



4 x
Belleville Washer

BENCH COMPONENTS:



1 x Right
Bench Leg



1 x Left
Bench Leg



1 x Bench Seat

ASSEMBLY:

The assembly is a two-person operation.

1. Inspect the shipping container contents for damage and to determine that all components and hardware are present.

2. Place the Bench Seat on the shipping packaging or other soft surface to avoid scratching the product.

Note: When viewing the Bench Seat from the edge, the mounting hole nearest the end of the span indicates the seat portion of the and the mounting hole toward the middle of the span indicates the back rest portion.

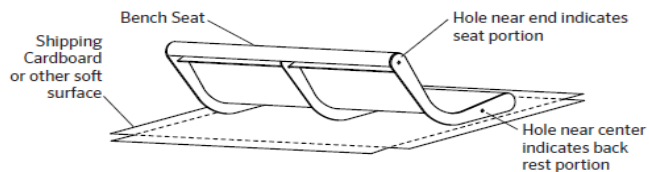

3. Position one of the Bench Legs near the appropriate end of the Bench Seat. Align the mounting holes in the Bench Leg Mounting Bosses with the mounting holes in the end of the Bench Seat.

Note: Before assembling the Bolts, it is recommended that a light oil or petroleum jelly be applied to the threads.

Place a concave Belleville Washer on one of the bolts. Make sure the concave face of the Belleville Washer is facing away from the Bolt head. Then put on one of the Flat Washers. Install the Bolt through the Bench Seat into the threaded hole in the Bench Leg Mounting Boss. Tighten the Bolt finger tight so that adjustments can be made.

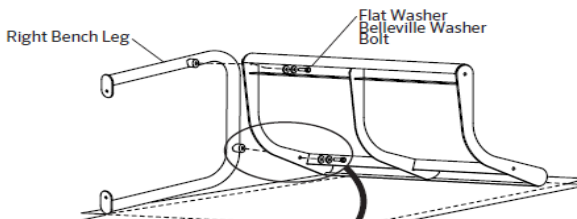

4. Install a Bolt and pair of Washers through the other set of mounting holes in that end of the Bench Seat and Bench Leg. Again, leave the hardware finger tight.

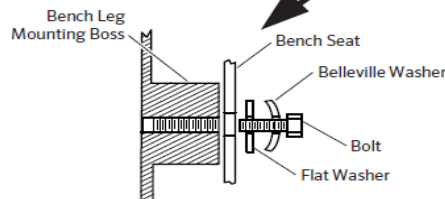

5. Attach the other Bench Leg to the other end of the Bench Seat in the same manner. Leave the hardware finger tight so adjustments can be made to level the Bench Seat.
6. After both Bench Legs are attached to the Bench Seat, turn the Bench right side up and tighten the Bolts while checking with a Level.

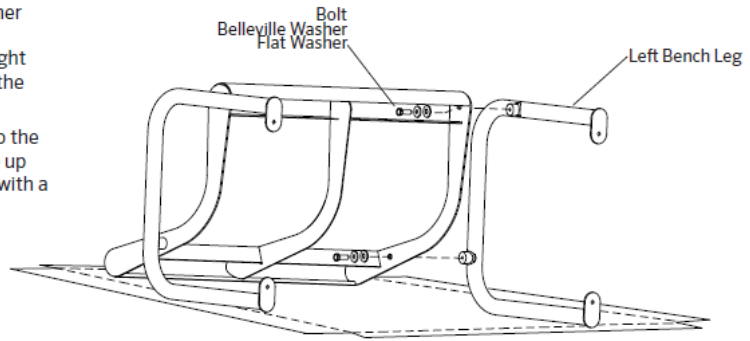

7. Move the Bench to the desired location.
- NOTE: The feet of the Bench include surface mounting holes in case a permanent installation is desired. Follow installation instructions provided with the hardware if purchased.
8. Retighten all of the hardware two weeks after initial assembly.

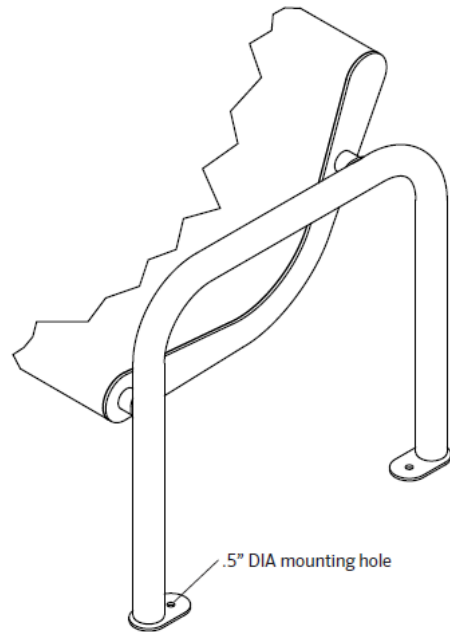

- Furniture must not be used other than for its intended purpose and should be inspected regularly for loose, missing, or broken hardware, and general instability.
- Furniture that is damaged or appears to be unstable must be removed from service and be repaired or replaced.
- Repairs must be made using only factory authorized parts and methods.

CARE AND MAINTENANCE

- Do not drag the assembled unit across any surface.
- This product requires only periodic cleaning with a sponge and a solution of mild detergent and water to remove surface dirt. Do not clean with a solvent or petroleum based products.