



anovafurnishings.com
888.535.5005 tel



F1062

ASSEMBLY INSTRUCTIONS

Victory Bench, Surface Mount

- F1052** 6' Expanded Steel Bench, Rolled Edge
- F1062** 6' Expanded Steel Bench, Traditional Edge
- F1065** 8' Expanded Steel Bench, Traditional Edge
- F3045** 4' Expanded Steel Deep Seat Bench, Traditional Edge
- F1339** 6' Expanded Steel Deep Seat Bench, Traditional Edge
- F3051** 8' Expanded Steel Deep Seat Bench, Traditional Edge
- D1062** 6' Perforated Steel Bench, Traditional Edge
- D1065** 8' Perforated Steel Bench, Traditional Edge
- C1062** 6' Perforated Steel Custom Bench, Traditional Edge
- C1062BB** 6' Perforated Steel Buddy Bench, Traditional Edge

TOOLS NEEDED:

- 1/2" Open-end or Box-end Wrench
- Ratchet with 1/2" Socket
- Level

ASSEMBLY HARDWARE:

- | | | |
|---|---|---|
|  |  |  |
| 8 x
5/16" X 1.5"
Hex Head Bolt | 8 x
5/16"
Flanged Hex Nut | 16 x
5/16"
Washer |

BENCH COMPONENTS:

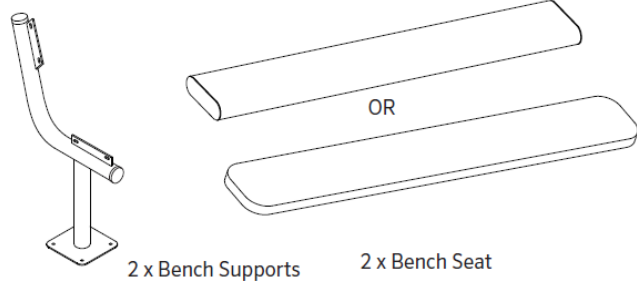

ASSEMBLY:

The assembly is a two-person operation.

1. Inspect the shipping container contents for damage and to determine that all components and hardware are present.

2. Place the Bench Supports and one of the Bench Seats on the shipping packaging or other soft surface to avoid scratching the product.
3. Align the mounting holes in one of the Bench Supports with the holes in the appropriate end of the Bench Seat. Install a Washer onto one of the provided Bolts and insert the Bolt through both parts, with the Bolt head on the outside surface of the Bench Support. Install a Washer and Nut on the inside end of the Bolt.

Leave the hardware finger tight so that adjustments can be made to level the bench seat.

Install a Bolt and Washer through the other set of mounting holes in that end of the Bench Support and Seat and install a Washer and Nut. Again, leave the hardware finger tight.

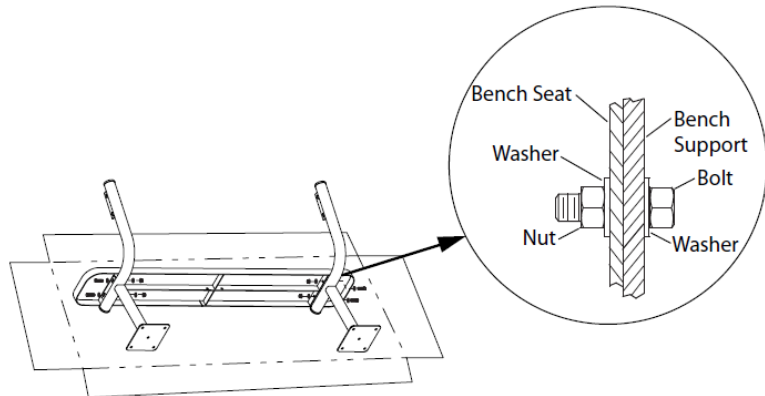

4. Attach the other Bench Support to the Bench Seat as shown. Leave the hardware finger tight so adjustments can be made to level the Bench Seat.

- The remaining Bench Seat becomes the Bench Back. Align the mounting holes in one of the Bench Supports with the holes in the appropriate end of the Bench Back. Install a Washer onto one of the Bolts and insert the Bolt through both parts, with the Bolt head on the outside surface of the Bench Support. Install a Washer and Nut on the inside end of the Bolt.

Leave the hardware finger tight so that adjustments can be made to level the Bench Back.

Install a Bolt and Washer through the other set of mounting holes in that end of the Bench Support and Back and install a Washer and Nut. Again, leave the hardware finger tight.

- Attach the other Bench Support to the Bench Back as shown. Leave the hardware finger tight so adjustments can be made to level the Bench Back.

- Tighten the Bench hardware using the Open End or Box End Wrench and Ratchet Wrench while checking the Seat surface with a Level; minor adjustments can be made while tightening the hardware to make the Seat level.

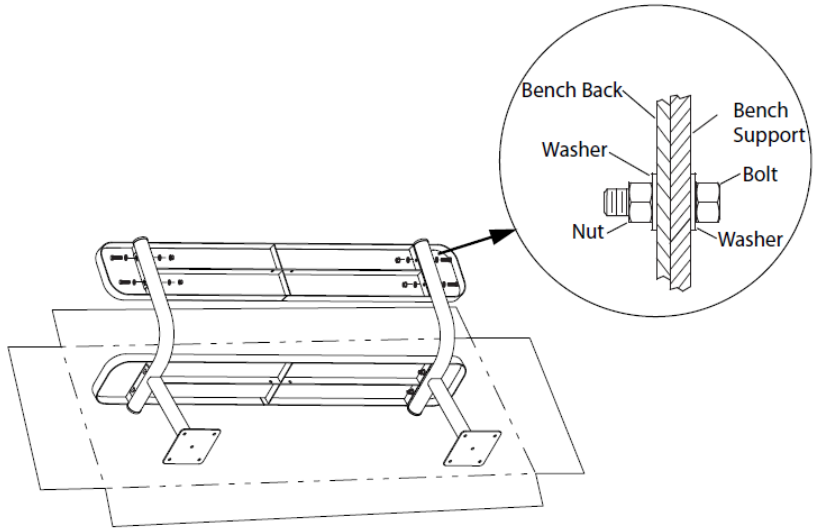

- Retighten all hardware two weeks after initial assembly.

The feet of the Bench Ends feature a surface mount bolt pattern for securing the Bench with customer supplied surface mount hardware.

Landscape Brands recommends the use of stainless steel fasteners and following the installation directions supplied with that hardware.

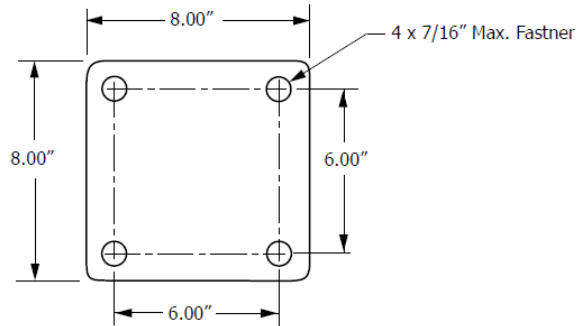

Surface mount bolt pattern dimensions



WARNING

- Furniture must not be used other than for its intended purpose and should be inspected regularly for loose, missing, or broken hardware, and general instability.
- Furniture that is damaged or appears to be unstable must be removed from service and be repaired or replaced.
- Repairs must be made using only factory authorized parts and methods.

CARE AND MAINTENANCE

- Do not drag the assembled unit across any surface.
- This product requires only periodic cleaning with a sponge and a solution of mild detergent and water to remove surface dirt. Do not clean with a solvent or petroleum based products.