

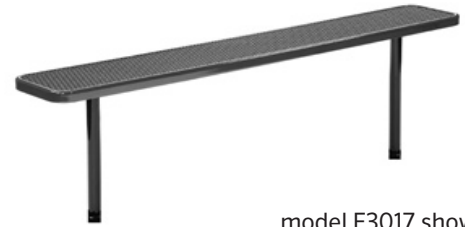

anovafurnishings.com
888.535.5005 tel

ASSEMBLY INSTRUCTIONS

F3017	6 ft Flat Bench
F3021	6 ft Flat Bench
F3024	8 ft Flat Bench
F3030	6 ft Flat Bench
F3033	8 ft Flat Bench
F3035	4 ft Flat Bench
F3040	8 ft Flat Bench
D3021	6 ft Flat Bench
D3024	8 ft Flat Bench



model F3017 shown
seat length and pattern
may vary

TOOLS NEEDED

- 1/2" Open-end or Box-end Wrench
- Ratchet with 1/2" Socket
- Level

ASSEMBLY HARDWARE:

		
4 x 5/16" X 1.25" Hex Head Bolt	8 x 5/16" Flat Washer	4 x 5/16" Flanged Hex Nut

BENCH COMPONENTS:

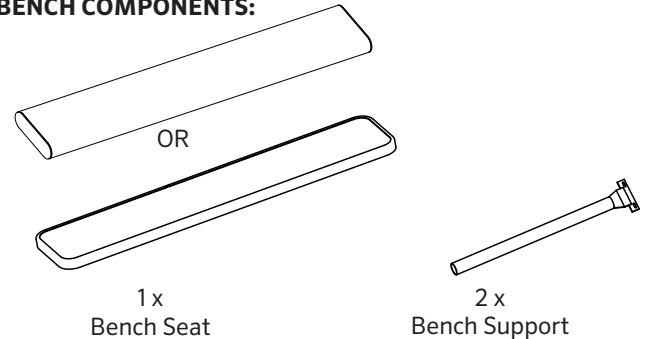

ASSEMBLY:

NOTE: Before assembling the Nuts to the Bolts, it is recommended that a light oil or petroleum jelly be applied to the Bolt threads.

1. Inspect the shipping container contents for damage and to determine that all components and hardware are present.

2. Place the Bench Seat upside down on the packaging cardboard or other soft surface. Position one of the Bench Supports near the end of the Seat.

3. Align the mounting holes in the bracket on the Bench Support with the mounting holes in the Bench Seat frame. Install a Washer onto one of the 1.25" long Bolts and insert the Bolt through both parts, with the Bolt head toward the outside surface of the Bench Seat. Install a Washer and Flanged Nut on the inside end of the Bolt.

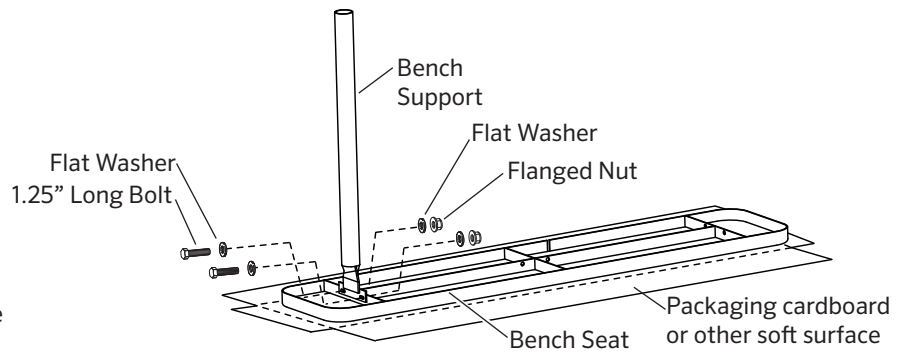

NOTE: Installing the Bolt in this direction reduces the risk of scratching during use.

Leave the hardware finger tight so that adjustments can be made.

Install a Bolt and Washer through the other set of mounting holes in that end of the Bench Seat frame and Bench Support bracket and install a Washer and Flanged Nut. Tighten the hardware.

4. Attach the other Bench Support to the Bench Seat in the same manner, installing the 1.25" long Bolts from the outside inward. Tighten the hardware after both Bolts are installed.

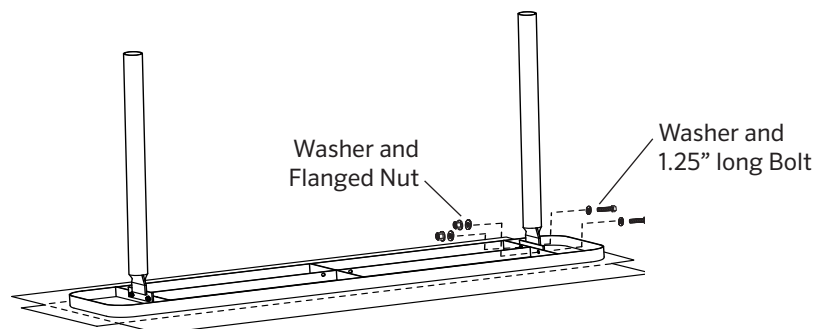

5. Determine the location for bench, locate underground utilities and avoid them while digging holes for the concrete bases.

6. The walls of the concrete base should be vertical and smooth to minimize the effects of frost upheaval. This can be achieved with the use of concrete forms, such as Sonotube. Consider extending the concrete base below the frost line to eliminate the possibility of frost upheaval. Consult a professional for loose or unusual soil conditions.

7. Create a temporary structure to support the Bench, at the desired height and level, while the concrete is curing.

8. Fill the forms with concrete and insert the Bench Supports, centered in the forms, until the Bench is supported by the temporary structure. Allow the Bench Supports to fill with concrete. Crown the concrete cap to optimize drainage.

9. After the concrete has cured remove the temporary structure and retighten all hardware.

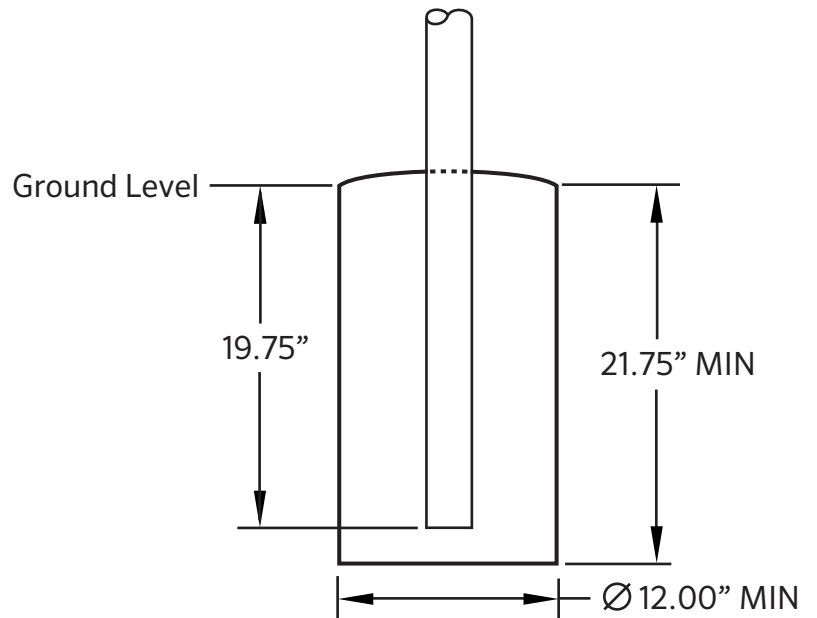

WARNING

- Furniture must not be used other than for its intended purpose and should be inspected regularly for loose, missing, or broken hardware, and general instability.
- Furniture that is damaged or appears to be unstable must be removed from service and be repaired or replaced.
- Repairs must be made using only factory authorized parts and methods.

CARE AND MAINTENANCE

- Do not drag the assembled unit across any surface.
- This product requires only periodic cleaning with a sponge and a solution of mild detergent and water to remove surface dirt. Do not clean with a solvent or petroleum based products.

