

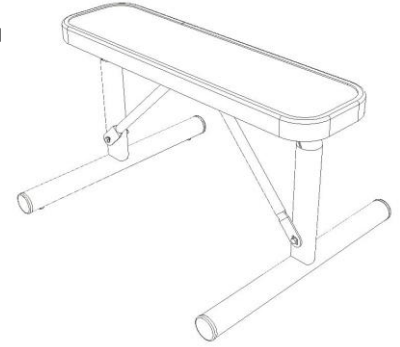

anovafurnishings.com
888.535.5005 tel

ASSEMBLY INSTRUCTIONS

- F6430** 3ft Expanded Steel Custom Flat Bench
- F3036** 3ft Expanded Steel Flat Bench
- F3041** 4ft Expanded Steel Deep Flat Bench
- F3018** 6ft Expanded Steel Deep Flat Bench
- F3020** 6ft Expanded Steel Flat Bench
- F3023** 8ft Expanded Steel Flat Bench
- D3020** 6ft Perforated Steel Flat Bench
- D3023** 8ft Perforated Steel Flat Bench



Model F6430 shown.
Seat length and pattern may vary

TOOLS NEEDED:

- Ratchet with 1/2" socket
- 1/2" Open end or box end wrench
- Rubber Mallet

BENCH COMPONENTS:



(1) Seat Platform

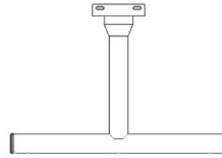

(2) Seat Support

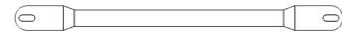

(2) Cross Brace

ASSEMBLY HARDWARE: All hardware is stainless steel.



(6) 5/16" x 1 1/4"
Hex Head Bolts

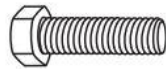

(2) 5/16" x 3"
Hex Head Bolts

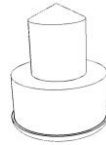

(4) Rubber Foot



(8) 5/16"
Nylock Nuts



(16) 5/16"
Flat Washers

ASSEMBLY:

The assembly is a two-person operation.

1. Inspect the shipping container contents for damage and to determine that all components and hardware are present.
2. Assemble the table over the shipping packaging or padded work area to avoid scratching the product.

NOTE: Before assembling the nuts to the bolts, it is recommended that a light oil or petroleum jelly be applied to the screw threads.

3. Locate the seat support and place the support on the work surface upside down with the seat platforms oriented downward.

4. Locate the rubber feet and insert 2 rubber feet into the bottom of each seat support with a rubber mallet.

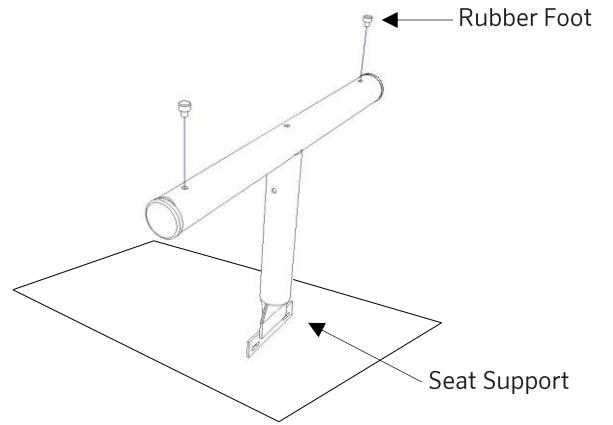

5. Locate the seat platform and the 2 seat supports. Align the mounting holes on the seat platform and the seat supports.

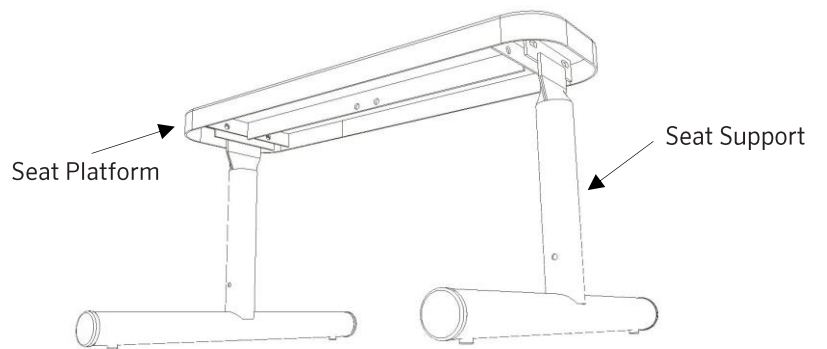

6. Install a 5/16" x 11/4" hex head bolt and a 5/16" flat washer through the seat support and the seat platform. Add a 5/16" flat washer and a 5/16" Nylock nut to each bolt. Tighten all hardware with a 1/2" socket wrench and a 1/2" open end or box end wrench.

Install the remaining seat supports in the same manner.

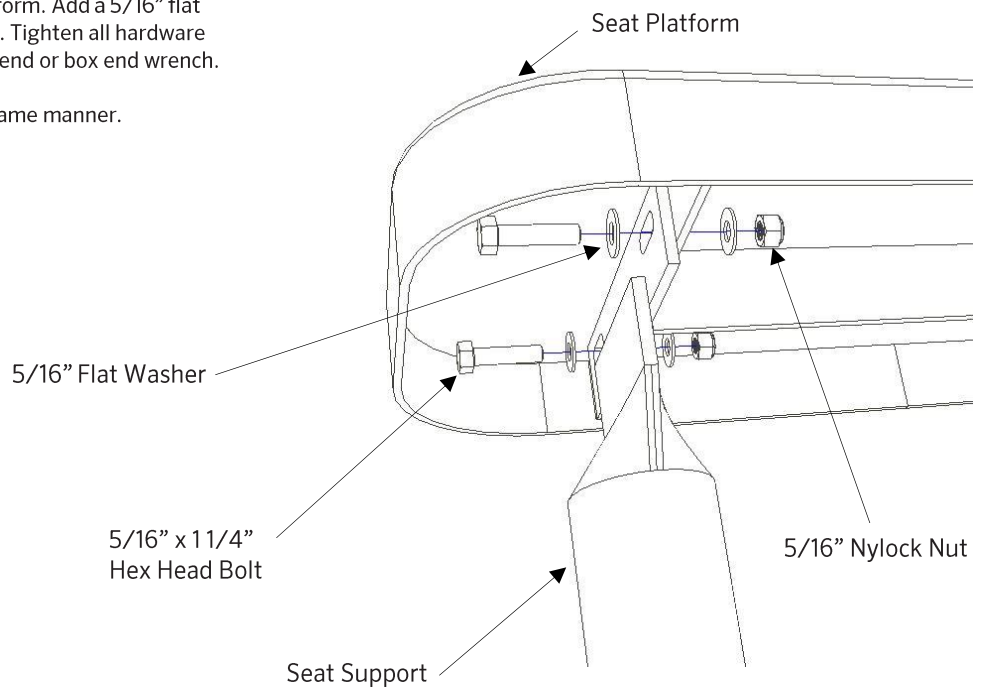

- Locate the two cross braces, align with the mounting hole on the seat platform and install a 5/16" x 1 1/4" hex head bolt and a 5/16" flat washer through the mount slot on the support bar and the mounting hole on the seat platform. Add a 5/16" flat washer and a 5/16" Nylock nut to the end of each bolt and leave finger tight. Align the mounting slot on the other end of the support bar with the mounting hole on the seat support and insert a 5/16" x 3" hex head bolt. Add a 5/16" flat washer and a 5/16" Nylock nut to the end of each bolt and leave finger tight. When all hardware has been installed, tighten with a 1/2" socket wrench and 1/2" open end or box end wrench.

Install the remaining cross braces in the same manner.

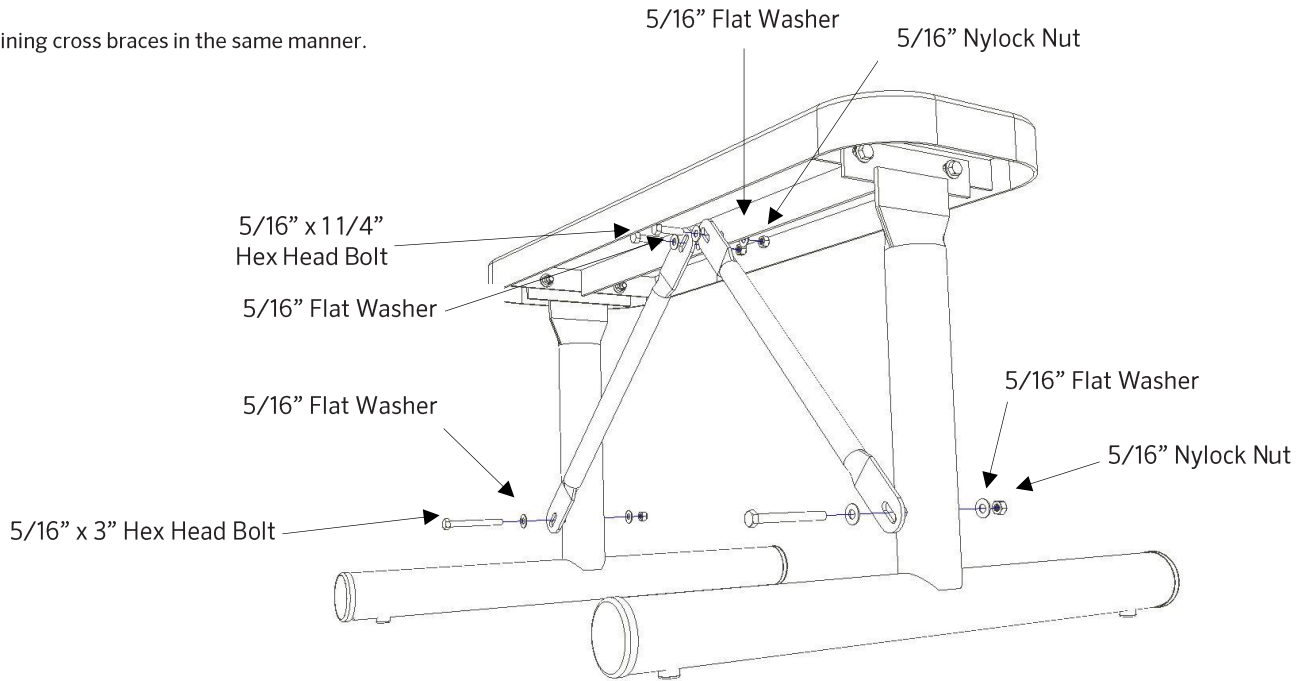

- Move the seat to the location where it will be used.

NOTE: This seat is required to be surface mounted prior to use. Follow surface mount instructions provided with the surface mount hardware that you purchase locally.

- After two weeks, retighten all hardware.

Note: Please contact Customer Care at 1-866-797-1761 when ordering replacement parts.



- Furniture must not be used other than for its intended purpose and should be inspected regularly for loose, missing, or broken hardware, and general instability.
- Furniture that is damaged or appears to be unstable must be removed from service and be repaired or replaced.
- Repairs must be made using only factory authorized parts and methods.

CARE AND MAINTENANCE

- Do not drag the assembled unit across any surface.
- This product requires only periodic cleaning with a sponge and a solution of mild detergent and water to remove surface dirt. Do not clean with a solvent or petroleum based products.