



211 North Lindbergh Blvd.
 St. Louis, MO 63141
 888.535.5005 tel
 314.754.0835 fax
specify@anovafurnishings.com
anovafurnishings.com



F2003 TRI2003 PICNIC TABLE

**6' expanded steel picnic table,
 traditional edge, flat bench seats,
 portable mount**

Accessories

8' Umbrella	7LPU
9' Umbrella	9LPU
1-Hole Hold Down Kit	A2375
2-Hole Hold Down Kit	A2376

Material

The table is 72.25" in length and features two flat bench seats. The table top and seats are 3/4 #9 expanded steel with a diamond shape pattern and feature a traditional edge. Table top and seats are protected by Fusion Advantage™, a plastisol coating with an average .125" thickness and a high-gloss powder coat. The table top is designed to support 100 lbs per square foot and the seats will support 200 lbs per linear foot. The table also features a 1.58" diameter umbrella hole in the center.

The frames are made of 2.38" O.D. steel tubing protected by a fade resistant powder coat finish featuring a state of the art primer proven to prevent rusting. The frame is portable in design allowing for flexibility in placement.

Finish

Fusion Advantage is a heat fused plastisol coating that creates an impervious rustproof barrier and resists UV deterioration, mildew, staining and fading.

The finish has been tested to the requirements of ASTM E1354 and is determined to be in compliance with California Uniform Fire Code 1103.2.1.4.2.

A state of the art primer is applied to all of the under supports, providing extreme rust fighting protection and durability. Treated components exceed the industry standard by 34% in testing by independent sources.

Color

See website or sales representative for color choices.

Assembly

Table requires some assembly. Stainless steel assembly hardware is included.

TRI2003 model includes tamper resistant and stainless steel assembly hardware

Maintenance

The product is virtually maintenance-free and requires only periodic cleaning with a sponge and a solution of mild detergent and water to remove surface dirt. Do not clean with solvent or petroleum based products.

Warranty

20-year limited structural warranty with 7-year finish warranty from the date of purchase. See full details on multi-year warranties for components at www.anovafurnishings.com/warranty.aspx.

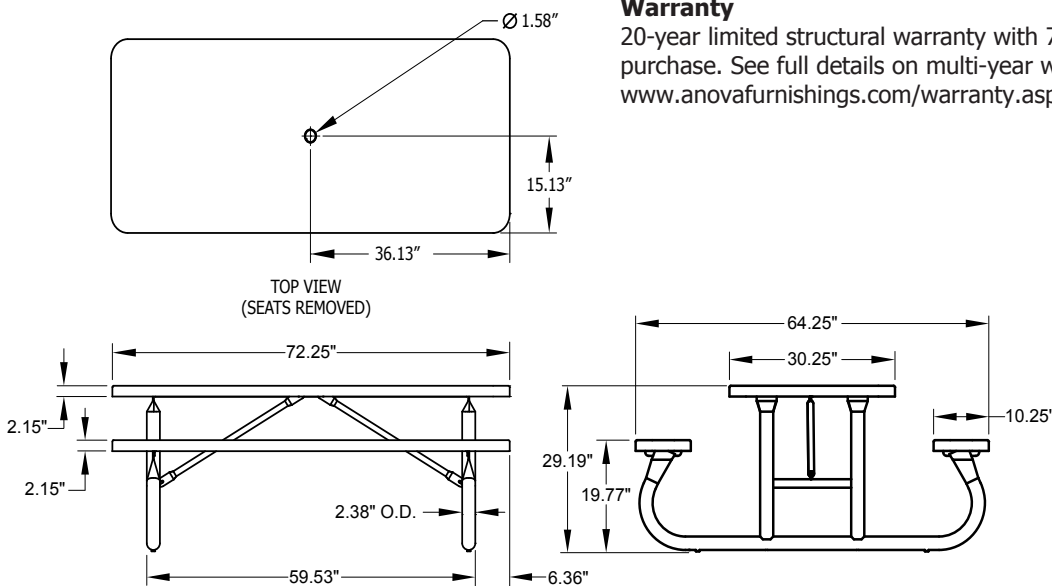

Shipping Information

Unit Wt.	Unit Shipping Wt. UPS	Unit Shipping Wt. Truck (1+ Units)	Unit Ship Size w/Pallet	Max Units per Pallet	Pallet Wt. (74" x 32")	Total No. Pkgs	Shipping Class
213 lbs	N/A	231 lbs/unit	20 cu. ft.	5	100 lbs	3	70