

Features

- Pilot Operated, Normally Open or Normally Closed.
- Snubber slows disc closing speed to protect system against water hammer damage more effectively than other techniques.
- Pressure spike due to water hammer reduced to a point eliminating the need for suppressors or other controls in most water systems.
- Fluid Controls Institute Inc. evaluations have classified these valves:

Pipe Sizes

3/8", 1/2", 3/4"

1", 1 1/4", 1 1/2", 2", 2 1/2"

FCI-82-1 Class

CC

BB

Construction

Valve Parts in Contact with Fluids	
Body	Brass
Disc	NBR
Seals	PTFE & NBR
Core Tube	305 Stainless Steel
Core and Plugnut	430F Stainless Steel
Springs	302 Stainless Steel
Piston	Stainless Steel or Brass
Shading Coil	Copper

Electrical

Standard Coil and Class of Insulation	Watt Rating and Power Consumption				Spare Coil Part No.			
	DC Watts	AC			General Purpose		Explosionproof	
		Watts	VA Holding	VA Inrush	AC	DC	AC	DC
F	11.6	6.1	16	30	238210	238710	238214	238714
F	16.8	16.1	35	95	272610	97617	272614	97617
F	22.6	-	-	-	-	238710	-	238714

Standard Voltages: 24, 120, 240, 480 volts AC, 60 Hz (or 110, 220 volts AC, 50 Hz).
6, 12, 24, 120, 240 volts DC. Must be specified when ordering. Other voltages are available when required.

Solenoid Enclosures

Standard: Red-Hat II - Watertight, Types 1, 2, 3, 3S, 4, and 4X; Red-Hat - Type I.

Optional: Red-Hat II - Explosionproof and Watertight, Types 3, 3S, 4, 4X, 6, 6P, 7, and 9; Red-Hat - Explosionproof and Raintight, Types 3, 7, and 9. (To order, add prefix "EF" to catalog number.)
See Optional Features Section for other available options.

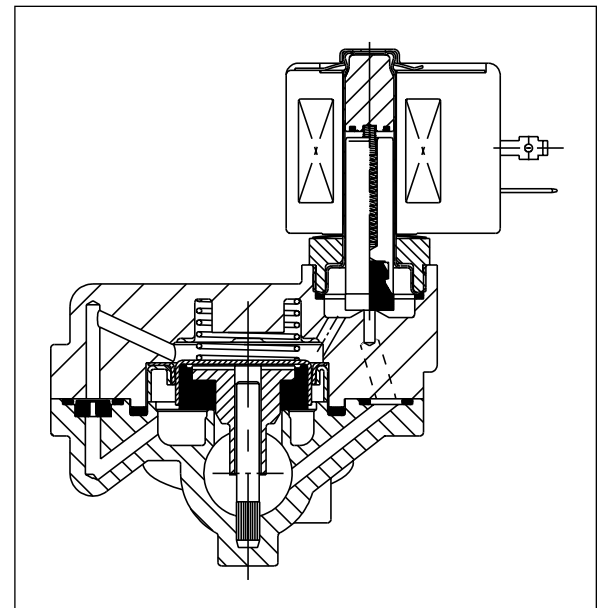
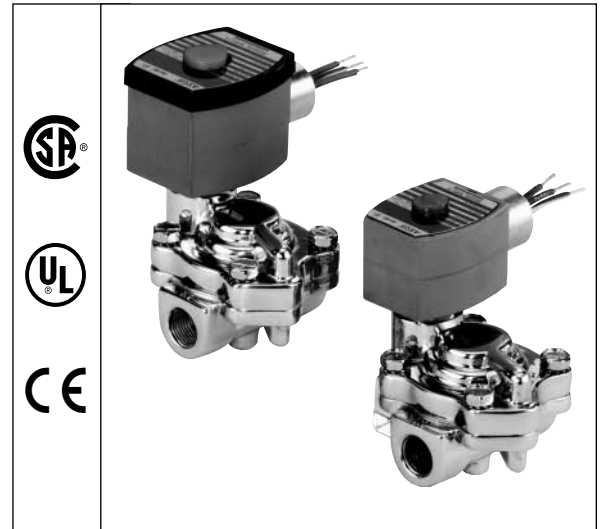

Nominal Ambient Temperature Ranges:

Red-Hat II/
Red-Hat AC: 32°F to 125°F (0°C to 52°C)

Red-Hat II DC: 32°F to 104°F (0°C to 40°C)

Red-Hat DC: 32°F to 77°F (0°C to 25°C)
(104°F/40°C occasionally)

Refer to Engineering Section for details.

Approvals:

CSA certified. UL listed, General Purpose Valves.

Red-Hat II meets applicable CE directives.

Refer to Engineering Section for details.

Specifications (English units)

Pipe Size (ins.)	Orifice Size (ins.)	Cv Flow Factor	Operating Pressure Differential (psi)			Maximum Fluid Temp. °F		Brass Body			Watt Rating/ Class of Coil Insulation ③	
			Min. ①	Max. AC	Max. DC	AC	DC	Catalog Number	Constr. Ref. No.	AC	DC	
				Water ②	Water ②							
NORMALLY CLOSED (Closed when de-energized)												
3/8	9/16	3	5	150	125	180	150	8221G1	1	6.1/F	11.6/F	
1/2	9/16	3.5	5	150	125	180	150	8221G3	1	6.1/F	11.6/F	
3/4	3/4	5.5	5	150	125	180	150	8221G5	2	6.1/F	11.6/F	
1	1	11.5	5	150	125	180	150	8221G7	5	6.1/F	11.6/F	
1 1/4	1 1/8	13	5	150	125	180	150	8221G9	6	6.1/F	11.6/F	
1 1/2	1 1/4	24	5	150	125	180	150	8221G11	7	6.1/F	11.6/F	
2	1 3/4	36	5	150	125	180	150	8221G13	11	6.1/F	22.6/F	
2 1/2	1 3/4	38	5	150	125	180	150	8221G15	12	6.1/F	22.6/F	
NORMALLY OPEN (Open when de-energized)												
3/8	9/16	3	5	-	125	-	150	822121	15	-	16.8/F	
3/8	9/16	3	5	150	-	180	-	8221G21	3	16.1/F	-	
1/2	9/16	3.5	5	-	125	-	150	822123	15	-	16.8/F	
1/2	9/16	3.5	5	150	-	180	-	8221G23	3	16.1/F	-	
3/4	3/4	5.5	5	-	125	-	150	822125	16	-	16.8/F	
3/4	3/4	5.5	5	150	-	180	-	8221G25	4	16.1/F	-	
1	1	11.5	5	-	125	-	150	822127	17	-	16.8/F	
1	1	11.5	5	150	-	180	-	8221G27	8	16.1/F	-	
1 1/4	1 1/8	13	5	-	125	-	150	822129	18	-	16.8/F	
1 1/4	1 1/8	13	5	150	-	180	-	8221G29	9	16.1/F	-	
1 1/2	1 1/4	24	5	-	125	-	150	822131	19	-	16.8/F	
1 1/2	1 1/4	24	5	150	-	180	-	8221G31	10	16.1/F	-	
2	1 3/4	36	5	-	125	-	150	822133	20	-	16.8/F	
2	1 3/4	36	5	150	-	180	-	8221G33	13	16.1/F	-	
2 1/2	1 3/4	38	5	-	125	-	150	822135	21	-	16.8/F	
2 1/2	1 3/4	38	5	150	-	180	-	8221G35	14	16.1/F		
Notes: ① Valves require a 5 psi Minimum Pressure Differential to open. Once open, they remain open with 3 psi differential pressure. ② Refer to Steam/Hot Water Valve Series for Hot Water constructions. ③ On 50 hertz service, the watt rating for the 6.1/F solenoid is 8.1 watts.												

Specifications (Metric units)

Pipe Size (ins.)	Orifice Size (mm)	Kv Flow Factor (m3/h)	Operating Pressure Differential (bar)			Maximum Fluid Temp. °C		Brass Body			Watt Rating/ Class of Coil Insulation ③	
			Min. ①	Max. AC	Max. DC	AC	DC	Catalog Number	Constr. Ref. No.	AC	DC	
				Water ②	Water ②							
NORMALLY CLOSED (Closed when de-energized)												
3/8	14	2.57	0.3	10	9	81	65	8221G1	1	6.1/F	11.6/F	
1/2	14	3.00	0.3	10	9	81	65	8221G3	1	6.1/F	11.6/F	
3/4	19	4.71	0.3	10	9	81	65	8221G5	2	6.1/F	11.6/F	
1	25	9.86	0.3	10	9	81	65	8221G7	5	6.1/F	11.6/F	
1 1/4	29	11.14	0.3	10	9	81	65	8221G9	6	6.1/F	11.6/F	
1 1/2	32	20.57	0.3	10	9	81	65	8221G11	7	6.1/F	11.6/F	
2	44	30.86	0.3	10	9	81	65	8221G13	11	6.1/F	22.6/F	
2 1/2	44	32.57	0.3	10	9	81	65	8221G15	12	6.1/F	22.6/F	
NORMALLY OPEN (Open when de-energized)												
3/8	14	2.57	0.3	-	9	-	65	822121	15	-	16.8/F	
3/8	14	2.57	0.3	10	-	81	-	8221G21	3	16.1/F	-	
1/2	14	3.00	0.3	-	9	-	65	822123	15	-	16.8/F	
1/2	14	3.00	0.3	10	-	81	-	8221G23	3	16.1/F	-	
3/4	19	4.71	0.3	-	9	-	65	822125	16	-	16.8/F	
3/4	19	4.71	0.3	10	-	81	-	8221G25	4	16.1/F	-	
1	25	9.86	0.3	-	9	-	65	822127	17	-	16.8/F	
1	25	9.86	0.3	10	-	81	-	8221G27	8	16.1/F	-	
1 1/4	29	11.14	0.3	-	9	-	65	822129	18	-	16.8/F	
1 1/4	29	11.14	0.3	10	-	81	-	8221G29	9	16.1/F	-	
1 1/2	32	20.57	0.3	-	9	-	65	822131	19	-	16.8/F	
1 1/2	32	20.57	0.3	10	-	81	-	8221G31	10	16.1/F	-	
2	44	30.86	0.3	-	9	-	65	822133	20	-	16.8/F	
2	44	30.86	0.3	10	-	81	-	8221G33	13	16.1/F	-	
2 1/2	44	32.57	0.3	-	9	-	65	822135	21	-	16.8/F	
2 1/2	44	32.57	0.3	10	-	81	-	8221G35	14	16.1/F	-	

Notes: ① Valves require a 0.3 bar Minimum Pressure Differential to open. Once open, they remain open with 0.2 bar differential pressure.
 ② Refer to Steam/Hot Water Valve Series for Hot Water constructions.
 ③ On 50 hertz service, the watt rating for the 6.1/F solenoid is 8.1 watts.

Dimensions: inches (mm)

Constr. Ref. No.		H	K	L	P	W
1	ins.	4.34	2.69	2.72	3.59	3.41
	mm	110	68	69	91	87
2	ins.	4.53	2.69	2.78	3.75	3.41
	mm	115	68	71	95	87
3	ins.	5.22	3.14	2.72	4.47	3.69
	mm	133	80	69	114	94
4	ins.	5.41	3.30	2.78	4.62	3.69
	mm	137	84	71	117	94
5	ins.	5.62	3.15	3.75	4.03	3.16
	mm	143	80	95	102	80
6	ins.	5.56	3.15	3.66	4.03	3.56
	mm	141	80	93	102	90
7	ins.	6.12	3.30	4.38	4.19	4.12
	mm	156	84	111	106	105
8	ins.	6.53	3.59	3.75	4.91	3.16
	mm	166	91	95	125	80
9	ins.	6.47	3.59	3.56	4.91	3.56
	mm	164	91	93	125	90
10	ins.	7.03	3.74	4.38	5.06	4.12
	mm	179	95	111	129	105
11	ins.	7.38	3.71	5.06	4.59	4.72
	mm	188	94	129	117	120
12	ins.	7.38	3.71	5.50	4.59	5.19
	mm	188	94	140	117	132
13	ins.	8.22	4.15	5.06	5.47	4.72
	mm	209	105	129	139	120
14	ins.	8.22	4.15	5.50	5.47	5.19
	mm	209	105	140	139	132
15	ins.	5.22	X	2.72	4.47	3.69
	mm	133	X	69	114	94
16	ins.	5.41	X	2.78	4.62	3.69
	mm	137	X	71	117	94
17	ins.	6.53	X	3.75	4.91	3.16
	mm	166	X	95	125	80
18	ins.	6.47	X	3.66	4.91	3.56
	mm	164	X	93	125	90
19	ins.	7.03	X	4.38	5.06	4.12
	mm	179	X	111	129	105
20	ins.	8.22	X	5.06	5.47	4.72
	mm	209	X	129	139	120
21	ins.	8.22	X	5.50	5.47	5.19
	mm	209	X	140	139	132

IMPORTANT: Valves may be mounted in any position.

Constr. Refs. 1, 2

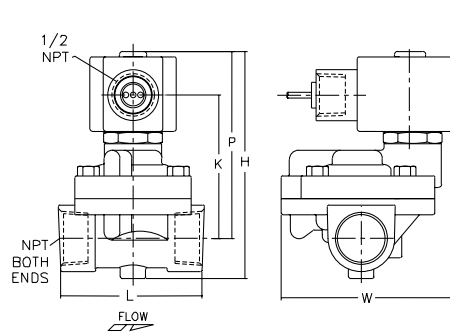

Constr. Refs. 15, 16

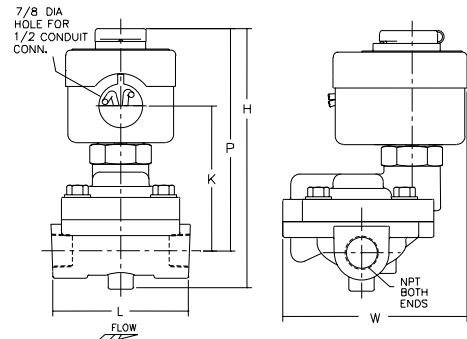

Constr. Refs. 3, 4

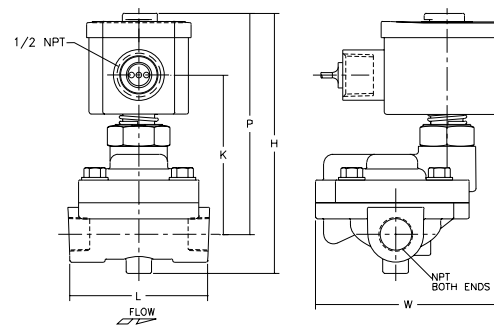

Constr. Refs. 8, 9, 10, 13, 14

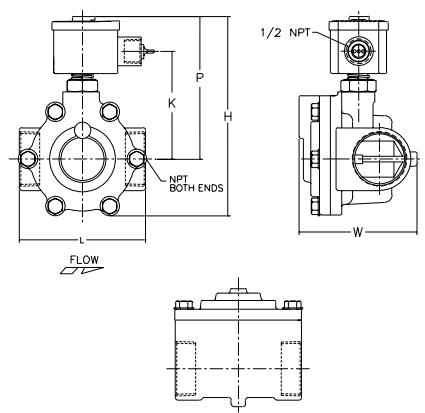

Constr. Refs. 5, 6, 7, 11, 12

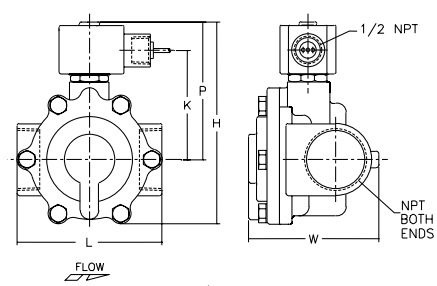

Constr. Refs. 17 - 21

