

AquaCal®

Installation Manual

HEATWAVE SUPERQUIET®



TropiCal
SWIMMING POOL / SPA HEAT PUMPS

Dial Display



Important

Read this document before operating / installing this product

For additional product manuals and operation / installation procedures, please visit www.AquaCal.com

MODEL / SERIAL NUMBER

Table of Contents

Contacting AquaCal AutoPilot, Inc.	1
Safety	1
1 - Installation	3
1.1 Positioning Equipment	3
1.2 Plumbing	4
1.2.a Plumbing Requirements	4
1.2.b Plumbing Diagrams	5
1.2.c Maintaining Ability to Winterize	7
1.2.d Water Connections to Heat Pump	7
1.2.e In-Line Chlorine Feeders	8
1.2.f Water Flow Rates	9
1.3 Electrical	10
1.3.a Electrical Requirements	10
1.3.b Incoming Power Access Holes	12
1.3.c Access Panels	12
1.3.d Verifying Transformer Setting (Select Units)	14
1.3.e Schematic Location	14
1.4 Connecting an External Controller (Optional)	14
1.4.a PoolSync®	15
1.4.b 2-WIRE Controllers (Pool-Spa)	15
2 - Appendix	16
2.1 Adjusting Water Flow Using ΔT (Delta-T)	16
2.2 Adjusting Water Pressure Switch (Select Units)	17
2.3 Available Accessories	18
2.4 Clearances	20
2.5 Dimensions	21
2.6 Identifying Model Specifications	22
2.7 Three-Phase Adjustment	24
2.8 Weights	24
2.9 Initial Heating Recommendations	25
2.10 Winterizing	25
3 - Troubleshooting	27
3.1 Fault Codes	27
3.2 Issues and Resolutions	30

Contacting AquaCal AutoPilot, Inc.

For further assistance, please contact the distributor or installer of this product.

If unavailable, please contact AquaCal® for a partner in your area. To better assist you, please have the heat pump model and serial number available.

Product Information:	
Website	www.AquaCal.com
Phone	(1) 727-823-5642
Hours	8-5 pm, Eastern M-F

Service Information:	
Website	www.AquaCal.com/request-heat-pump-service/

SAFETY

- For personal safety, and to avoid damage to equipment, follow all safety instructions displayed on the equipment and within this manual. Repair and service of heat pump must be performed by an authorized service center.
- Warranties may be voided if the equipment has been improperly installed, maintained or serviced.
- If service is deemed necessary, please contact AquaCal.

SAFETY SIGNALS

Throughout this document, safety signals have been placed where particular attention is required.

 **DANGER**

Failure to heed the following will result in injury or death.

 **WARNING**

Failure to heed the following may result in injury or death.

 **NOTICE**

Failure to heed the following may result in damage to equipment.

When installing and using your heat pump basic safety precautions must always be followed, including the following:

 **DANGER**

Failure to heed the following will result in injury or death.

- The heat pump utilizes high voltage and rotating equipment. Use caution when servicing.
- Follow all National Electric Codes (NEC) and/or State and Local guidelines.

WARNING

Failure to heed the following may result in injury or death.

- Installation and repairs must be performed by a qualified technician.
- The heat pump contains refrigerant under pressure. Repairs to the refrigerant circuit must not be attempted by untrained and/or unqualified individuals. Service must be performed only by qualified HVAC technicians. Recover refrigerant before opening the system.
- Improper water chemistry can present a serious health hazard. To avoid possible hazards, maintain pool/spa water per standards as detailed in the product's operation manual.
- Prolonged immersion in water warmer than normal body temperature may cause a condition known as Hyperthermia. The symptoms of Hyperthermia include unawareness of impending hazard, failure to perceive heat, failure to recognize the need to exit the pool or spa, and unconsciousness. The use of alcohol, drugs, or medication can greatly increase the risk of fatal Hyperthermia. People having an adverse medical history, or pregnant women should consult a physician before using a hot tub or spa. Children and the elderly should be supervised by a responsible adult.
- This appliance is not to be used by persons (including children) with reduced physical, sensory, or mental capabilities, or lack of experience and knowledge, unless they have been given supervision or instruction.
- Children must be supervised and are not to play with the appliance.

NOTICE

Failure to heed the following may result in damage to equipment.

- Maintain proper water chemistry to avoid damage to the pump, filter, pool shell, etc.
- Water flow exceeding the maximum flow rate requires a bypass. Damage due to excessive water flow will void the warranty.
- Failure to protect equipment against corrosive conditions will adversely affect the life of the equipment and will void equipment warranty.

SAVE THESE INSTRUCTIONS

1 - Installation

DANGER

Failure to heed the following will result in injury or death.

- Deactivate power while routing wiring to control board.
- Follow all National Electric Codes (NEC) and/or State and Local guidelines.

WARNING

Failure to heed the following may result in injury or death.

- Installation of this equipment by anyone other than a qualified installer can result in a safety hazard.
- The information contained throughout the "Installation" section is intended for use by qualified installation technicians familiar with the swimming Pool/Spa safety standards.

NOTICE

Failure to heed the following may result in damage to equipment.

- Failure to protect equipment against corrosive conditions will adversely affect the life of the equipment and will void equipment warranty.
- Do not install equipment inside of a building.

IN THIS SECTION:

1.1 Positioning Equipment	3
1.2 Plumbing	4
1.3 Electrical	10
1.4 Connecting an External Controller (Optional)	14

1.1 Positioning Equipment

NOTICE

Failure to heed the following may result in damage to equipment.

- Do not install equipment inside of a building.

Outdoor Use Only

Do not install equipment inside of a room or building.

- Heat Pumps require unobstructed airflow for proper operation. Heat Pumps should never be installed indoors or in a location where airflow is restricted.
- If an indoor installation is being considered, the installer and dealer are strongly urged to contact the AquaCal Application Department, or a local Professional Engineer prior to proceeding.
- See "Clearances"

Controlling Irrigation and Rainwater Runoff

- Irrigation water may damage heat pump components. Direct irrigation water away from the heat pump.
- The heat pump will withstand normal rainfall. Do not allow a roof slope to direct rainwater onto the heat pump. Have a gutter installed on the roof edge to direct this water away from the heat pump. Or install the heat pump in another location.

Planning for Condensation

The heat pump can produce a large amount of condensation. The amount of water depends on air temperature and humidity.

- Install the heat pump with enough height to allow for water drainage.
- Plan for water drainage as needed.
 - See "*Condensation Drain Kit (# STK0202)*" on page 18.

Mounting Pad Requirements

- The heat pump's base must be installed on a flat and level surface that completely supports the entire base.
- Build the heat pump pad out of concrete or other code-approved material.
- Confirm the pad can support the weight of the heat pump.
- Elevate the pad enough to allow for drainage.
- Make sure the pad is flat and level.
- Have the pad support the entire heat pump base in all directions.
- Do not install the heat pump on soil or grass.
- Do not allow the heat pump base to touch the building's foundation.
- Do not place the heat pump directly on a concrete floor. This can cause noise to be transmitted to an occupied space. If necessary install vibration dampers between the heat pump base and floor.
- Equipment pad must meet all requirements of authorities having code-related jurisdiction.

Anchoring to Pad

- Follow all applicable local, state, and national requirements regarding wind load anchoring.
- The shipping brackets used to secure the heat pump to the pallet are approved mounting (hurricane) brackets. They should be used to anchor the heat pump to the pad.
- If needed, contact AquaCal® to obtain anchoring kit information. Please have the heat pump model number and serial number when requesting support.

1.2 Plumbing

1.2.a Plumbing Requirements

- The heat pump must receive water flow under worst-case conditions such as a fouled water filter.
- Failure to provide clean filtered water to the heat pump can void the product warranty.
- Water flow exceeding maximum flow rates will negatively affect the total pool filtration performance and may damage the heat pump. This will not be covered under the equipment warranty. See "*Water Flow Rates*" on page 9.
 - Install a bypass valve whenever water-flow may exceed the maximum rating.
 - See "*Bypass Valve Kit (# STK0135)*" on page 18.
 - For additional guidance testing water flow rates, please contact AquaCal®.
- A safety-enhancing "Over Temperature Alarm" kit is strongly recommended for all spa applications. See "*Over Temperature Alarm Kit*" on page 19.

1.2.b Plumbing Diagrams

Plumbing diagrams are provided in this section as a planning guide to the sequence of equipment, valves, and fittings.

- The basic plumbing configurations for typical installations are shown.
- If the installation does not closely follow any of the supplied plumbing diagrams, AquaCal® Technical Support is available for installation advice and guidance.
- Confirm water provided to the heat pump is clean and filtered.

Heat Pump with water flows equal or less than the maximum listed flow rate

See "Water Flow Rates" on page 9.

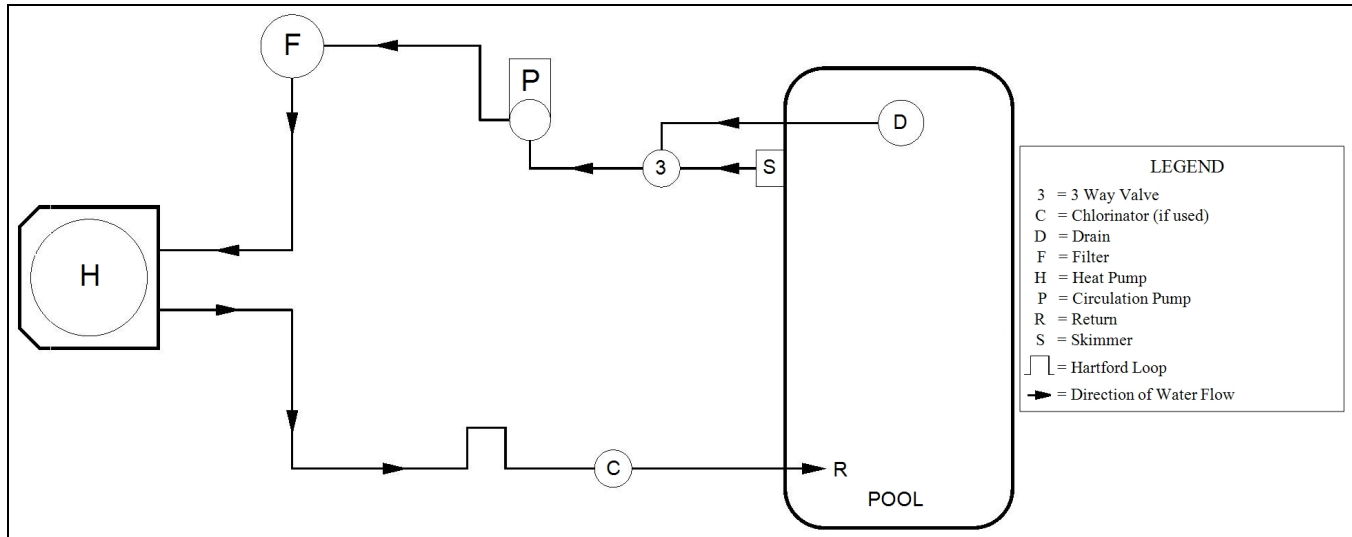

Heat Pump with water flows greater than the maximum listed flow rate

See "Water Flow Rates" on page 9.

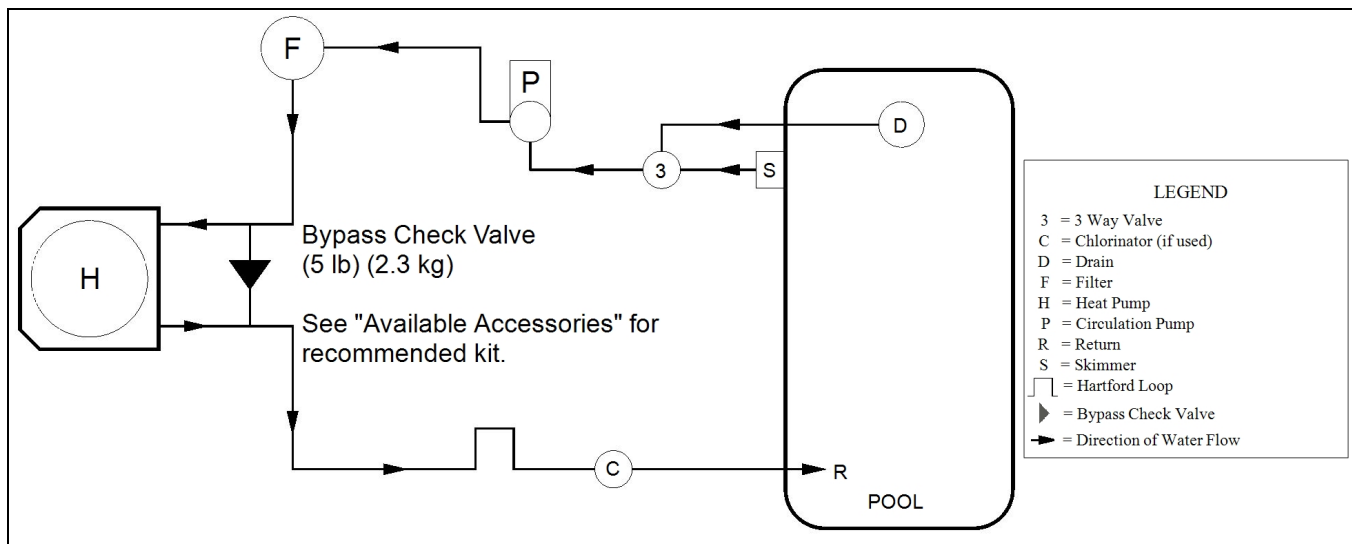

Heat Pump with Spillover Spa (One filter Pump)

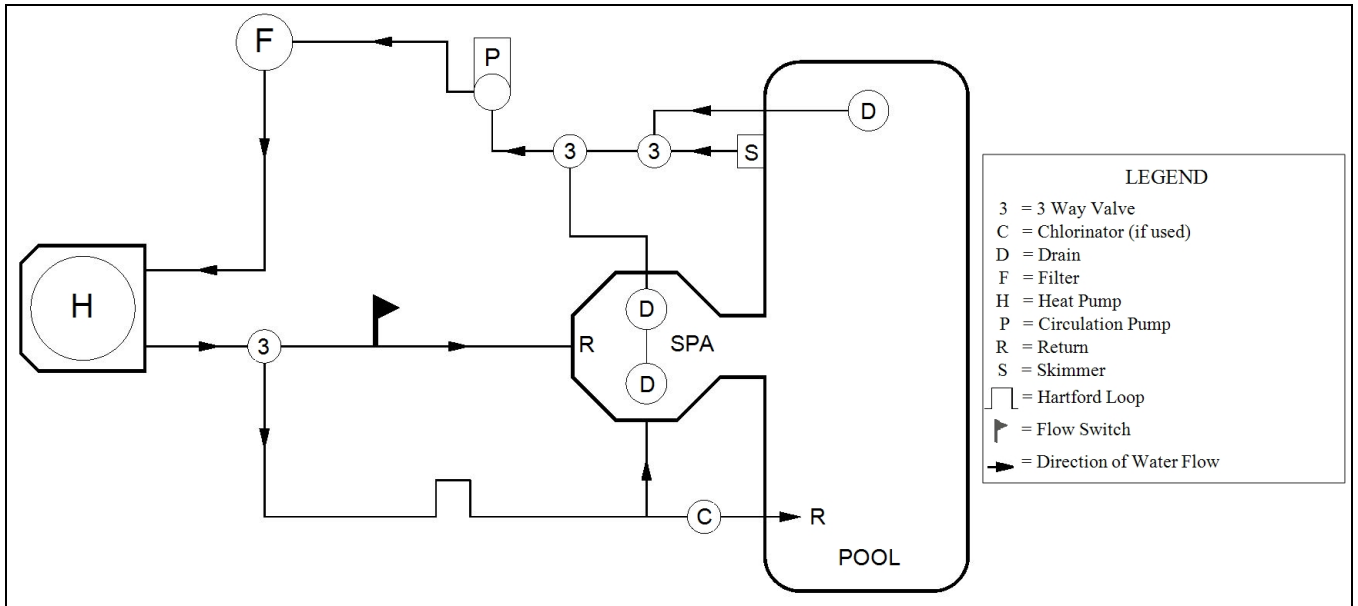

Heat Pump with Spillover Spa (Two filter Pumps)

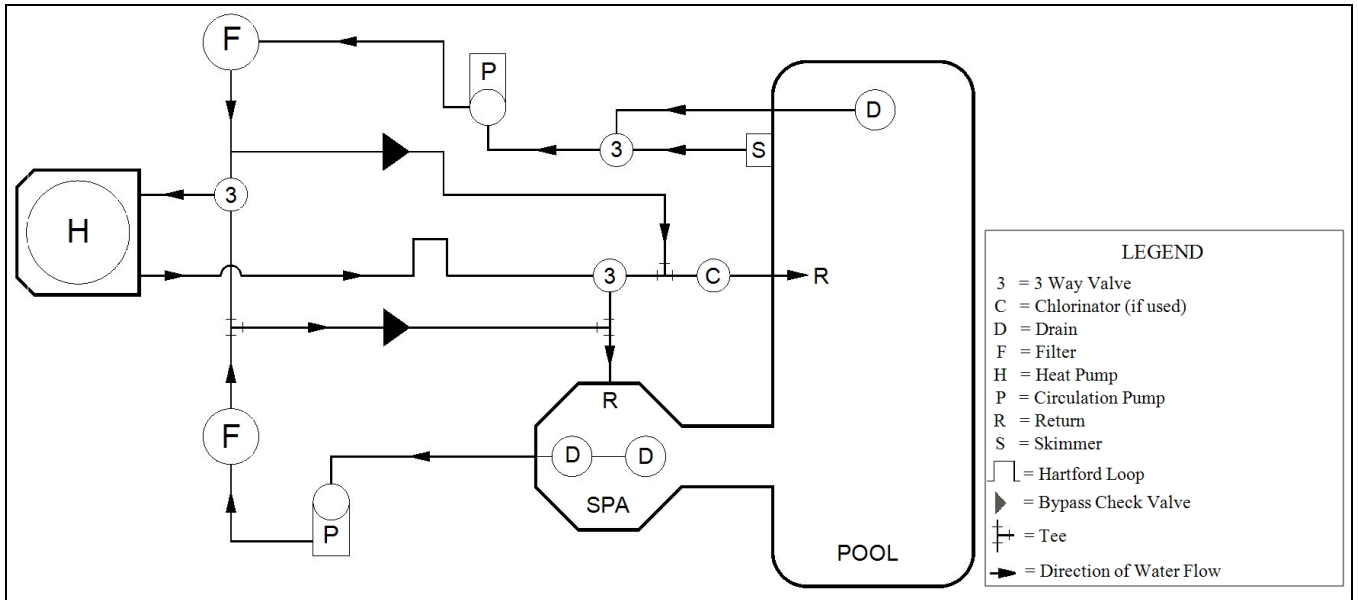

Heat Pump with Solar Panels in Plumbing Circuit

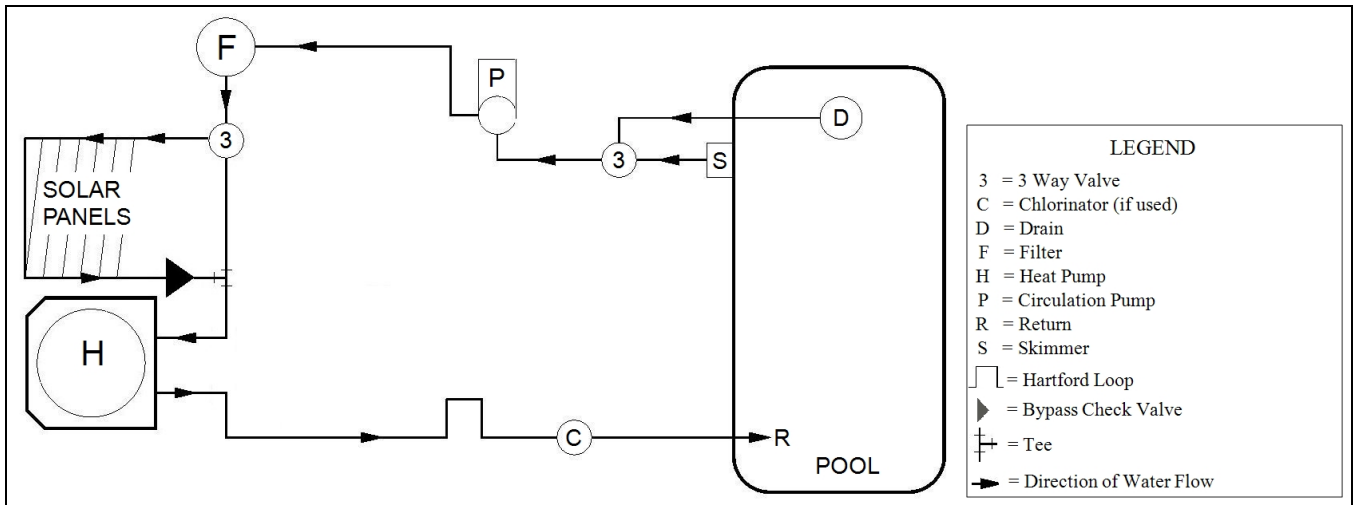

Heat Pump with Gas Heater backup

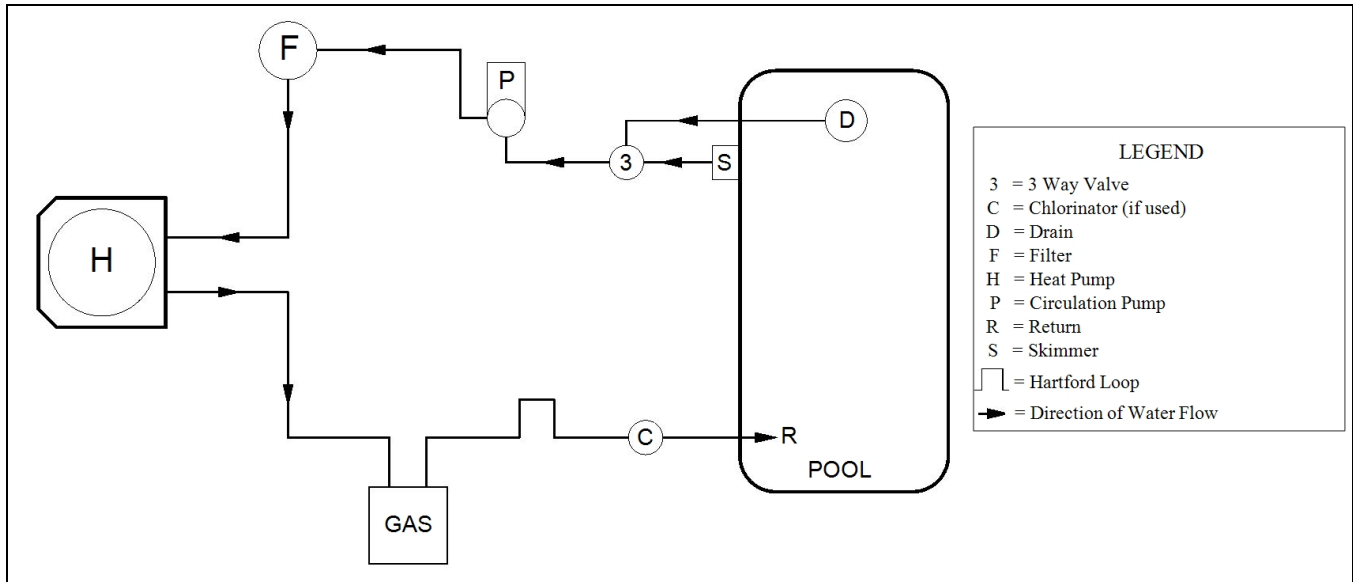

Multiple Air Source Heat Pumps

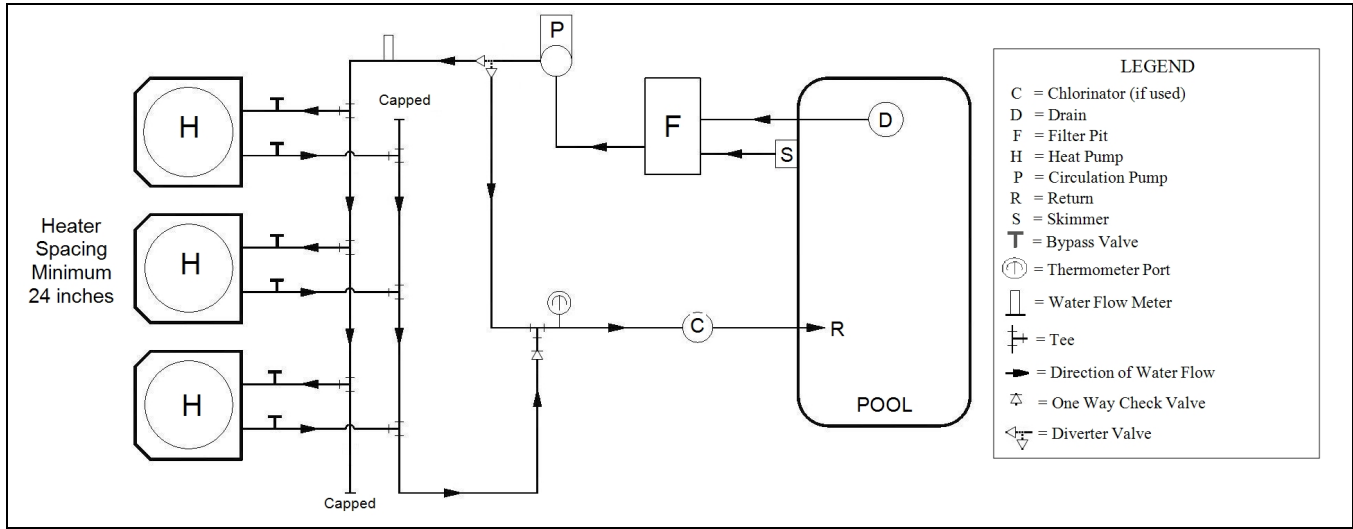

1.2.c Maintaining Ability to Winterize

Do not use glue on the threaded portion of the equipment's unions. A glued-in-place union will prevent the equipment from being properly winterized.

1.2.d Water Connections to Heat Pump

- Heat Pump union sizes are specified on diagrams.
- Connections to site plumbing are made via PVC solvent cement to the female slip socket of the plumbing unions.
- Plumbing unions are available from AquaCal®.

NOTICE

Failure to heed the following may result in damage to equipment.

- Do not use glue on the threaded portion of the equipment's unions. A glued-in-place union will prevent the equipment from being properly winterized.

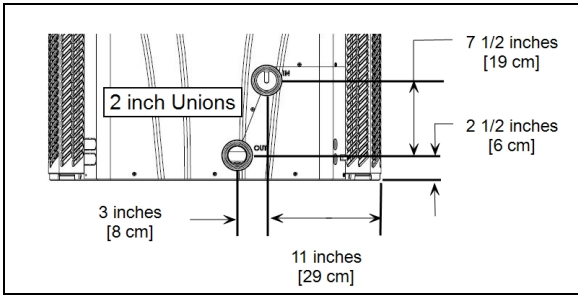

HeatWave SuperQuiet® SQ120R, SQ125, SQ145, SQ166R and SQ225

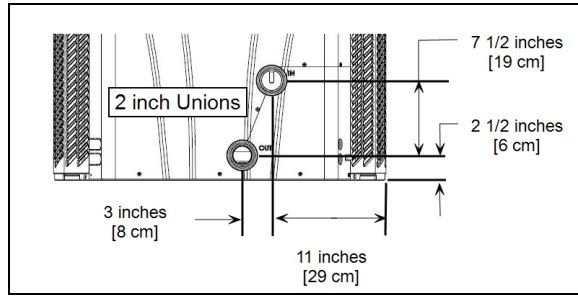

TropiCal® T090, T115, T135

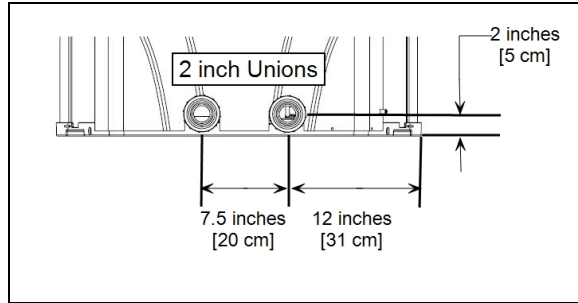

TropiCal® T035, T055, T075

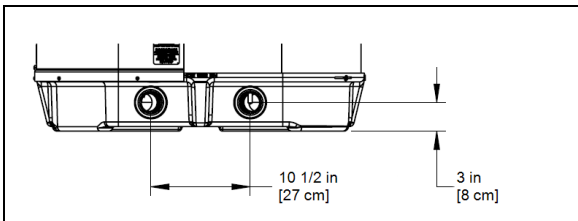

TropiCal® T170

1.2.e In-Line Chlorine Feeders

Place in-line chlorinators downstream from the heat pump and as low in elevation as possible.

- If an erosion type feeder is used, it is recommended that a Hartford Loop be installed to protect internal heat pump components.
- A Hartford Loop is not required when using a Salt Chlorine Generator.
- Avoid storing corrosive chemicals near the heat pump to minimize potential damage to the exterior of the heat pump.

Heat Pump with Erosion Tablet Feeder and Hartford Loop

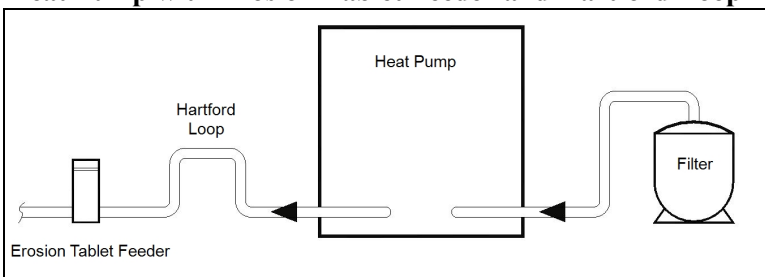

1.2.f Water Flow Rates

Maintain water flow rates as indicated. Please note, these specifications relate to the heat pump only. Code-specified whole system turnover rates must be satisfied.

NOTICE

Failure to heed the following may result in damage to equipment.

- Water flow exceeding maximum flow rates will negatively affect the total pool filtration performance and may damage the heat pump. This will not be covered under the equipment warranty.

MODEL	HEAT EXCHANGER TYPE	FLOW RATES	
		MINIMUM	MAXIMUM
SQ125	Titanium ThermoLink [®]	30 GPM (113.6 L/min)	70 GPM (265 L/min)
SQ145	Titanium ThermoLink [®]	30 GPM (113.6 L/min)	70 GPM (265 L/min)
SQ225	Titanium ThermoLink [®]	30 GPM (113.6 L/min)	70 GPM (265 L/min)
T035	Titanium Tube-in-Tube	20 GPM (75.7 L/min)	45 GPM (170 L/min)
T055	Titanium Tube-in-Tube	20 GPM (75.7 L/min)	45 GPM (170 L/min)
T075	Titanium Tube-in-Tube	20 GPM (75.7 L/min)	45 GPM (170 L/min)
T090	Titanium ThermoLink [®]	30 GPM (113.6 L/min)	70 GPM (265 L/min)
T115	Titanium ThermoLink [®]	30 GPM (113.6 L/min)	70 GPM (265 L/min)
T135	Titanium ThermoLink [®]	30 GPM (113.6 L/min)	70 GPM (265 L/min)
T170	Titanium Tube-in-Tube	30 GPM (113.6 L/min)	70 GPM (265 L/min)

PLEASE NOTE -

If minimum flow rates are not met, heat pump performance is reduced and performance will suffer. Internal safety devices may deactivate the heat pump with the following errors:

- Operate water filtration devices per manufacturer's specifications. Dirty filters can cause a reduction of water flow to the heat pump. An increase of 7-10 psi (48 to 69 kPa) higher than the clean filter pressure typically reduces flow rates. This requires the filter to be cleaned or back-washed.
- Keep baskets free of debris. A large quantity of debris in the pump and skimmer baskets can reduce water flow.
- Check for improper valve settings. A partially closed valve after the filter, or a full-open bypass around the heat pump, will cause insufficient water flow through the heat pump.
- The maximum static pressure (or operating pressure) is 50 psi (345 kPa). These specifications relate to the heat pump only.
- Code-specified whole system turnover rates must be satisfied.

1.3 Electrical

DANGER

Failure to heed the following will result in injury or death.

- Deactivate power while routing wiring to control board.
- Follow all National Electric Codes (NEC) and/or State and Local guidelines.

WARNING

Failure to heed the following may result in injury or death.

- The information contained in this section is intended for use by qualified electricians familiar with electrical service-industry safety standards and methods.
- Locate the equipment disconnect as near to the heat pump as possible. Always satisfy applicable codes and standards.
- Never mount power-disconnects directly to the heat pump.
- In sizing power wiring, be especially aware of up-sizing requirements necessary due to wiring distances. Always satisfy applicable codes and standards.
- AquaCal® heat pumps are designed to use copper conductors, only. Do not use aluminum wire.

1.3.a Electrical Requirements

Standards

Standards	Title
NFPA 70, Nat'l Elec. Code 2017	The electrical installation must conform to the current version of the National Electric Code (NEC), and all applicable local and state codes
IEC 60335-1	Household and similar electrical appliances - Safety - General Requirements
IEC 60335-2	Household and similar electrical appliances - Safety – Particular requirements for electrical heat pumps, air-conditioners, and dehumidifiers
UL 1995 & CSA C22.2 No. 236-15	Standard for Safety - Heating and cooling equipment

Table 1 - Standards

Grounding and Bonding

Follow local code requirements for proper grounding and bonding of heat pump equipment.

- A bonding lug has been provided on the heat pump.

Surge Suppression

The use of approved commercial surge protectors is strongly recommended.

Sizing the Electrical Service

Refer to equipment data plate for specific information required to size electrical service and over-current protection of the heat pump. Sizing is based on data plate information, wire size, wiring devices, and over-current protection per applicable local codes and standards.

Minimum and Maximum Operating Voltage

The heat pump must operate within specified voltages.

NOTICE

Failure to heed the following may result in damage to equipment.

- Operating equipment under higher or lower voltage conditions may result in damage to your compressor, motors or other electrical components. This damage will not be covered by the product warranty.
1. Measure site voltage. The site voltage **MUST** be measured under “FULL LOAD” conditions. Activate all equipment using the same electrical panel as the heat pump.
 2. If measured site voltage is outside listed ranges, immediately deactivate equipment until site conditions have been corrected. If unsure of heat pump equipment rating, please

Equipment Rating	Minimum Site Voltage	Maximum Site Voltage
A Voltage (208 to 230 Volts) Single Phase 60 hertz	200 Volts	253 Volts
B Voltage (208 to 230 Volts) Three Phase 60 hertz	200 Volts	253 Volts
D Voltage (380 to 420 Volts) Three Phase 50 hertz	361 Volts	441 Volts
E Voltage (380 Volts) Three Phase 60 hertz	361 Volts	399 Volts
G Voltage (460 Volts) Three Phase 60 hertz	437 Volts	483 Volts
H Voltage (200 to 240 Volts) Single Phase 50 hertz	180 Volts	264 Volts

1.3.b Incoming Power Access Holes

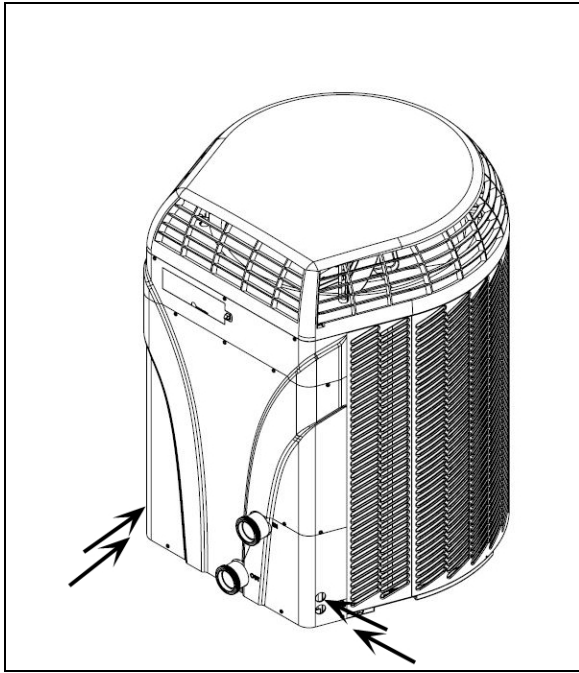

HeatWave SuperQuiet® SQ120R, SQ125, SQ145, SQ166R and SQ225

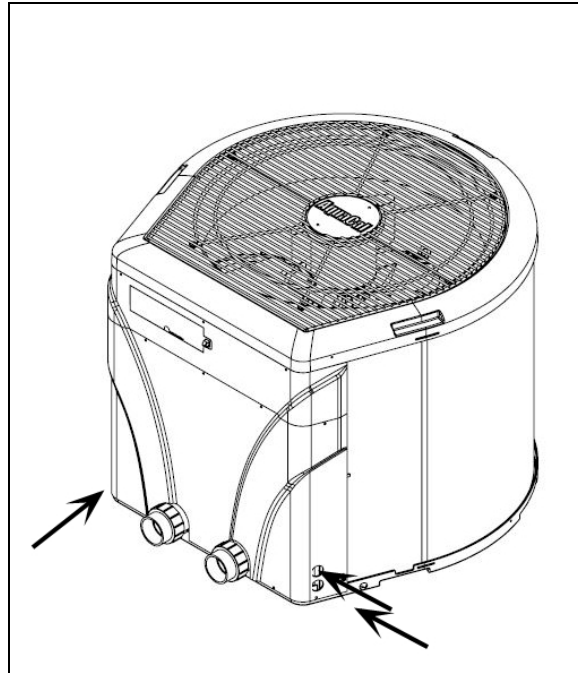

TropiCal® T035, T055, T075

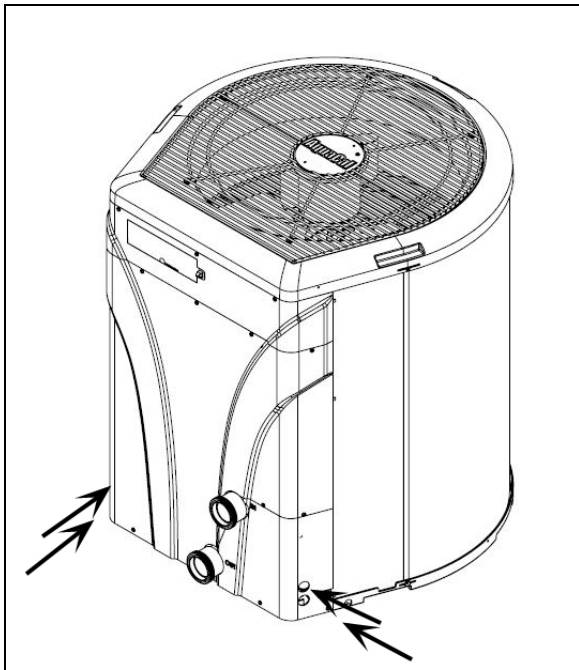

TropiCal® T090, T115, T135

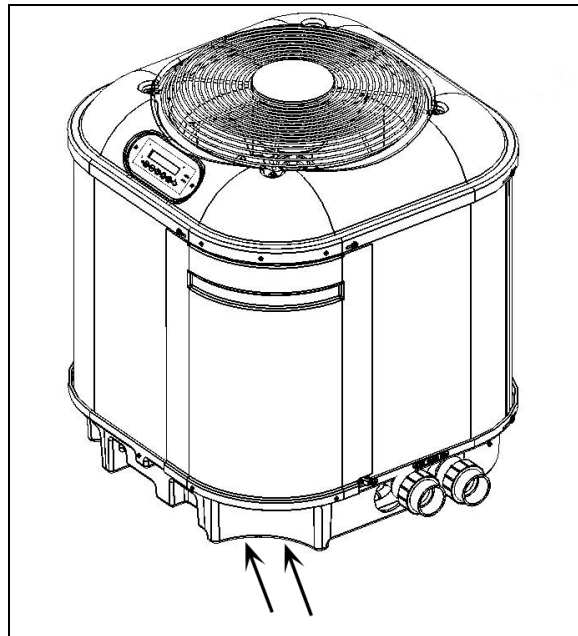

TropiCal® T170

1.3.c Access Panels



Failure to heed the following will result in injury or death.

- Deactivate power while routing wiring to control board.
- Follow all National Electric Codes (NEC) and/or State and Local guidelines.

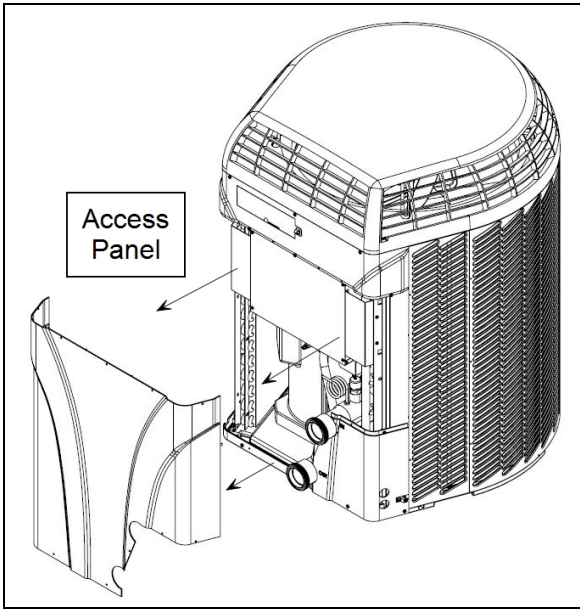

HeatWave SuperQuiet® SQ120R, SQ125, SQ145, SQ166R and SQ225

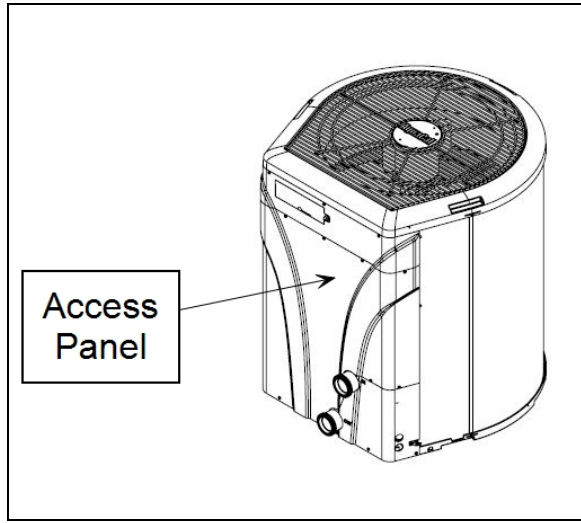

TropiCal® T090, T115, T135

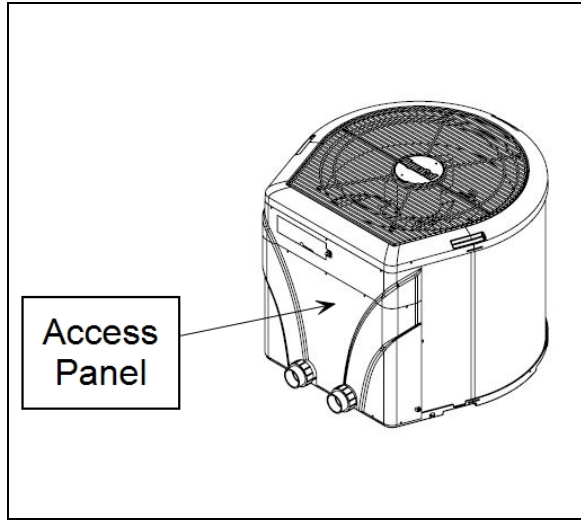

TropiCal® T035, T055, T075

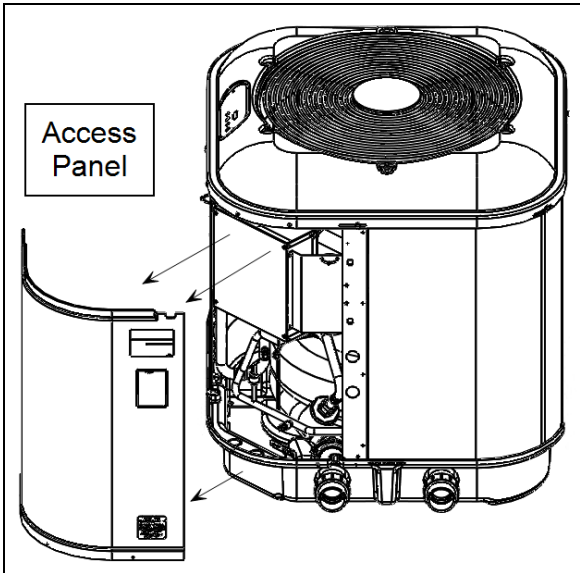

TropiCal® T170

1.3.d Verifying Transformer Setting (Select Units)

Transformer voltage must be confirmed and set correctly depending on the measured voltage found on the site. Incorrect settings may cause heat pump damage. The following procedure will allow the installer to set the heat pump's transformer for the appropriate site voltage.

! DANGER

Failure to heed the following will result in injury or death.

- Deactivate power while routing wiring to control board.
- Follow all National Electric Codes (NEC) and/or State and Local guidelines.

! WARNING

Failure to heed the following may result in injury or death.

- The information contained in this section is intended for use by qualified technicians, familiar with electrical service-industry safety standards and methods.

1. Turn heat pump on by adjusting the thermostat to call for heating or cooling. If more than one heat pump is on-site, turn them all on. Allow time for all heat pump compressors to activate.
2. Measure the running site voltage.
3. Confirm transformer tap is set for the measured site voltage. If more than one voltage tap is shown, select the voltage nearest to the running site voltage.

**Example of heat pump transformer
(Varies between models)**

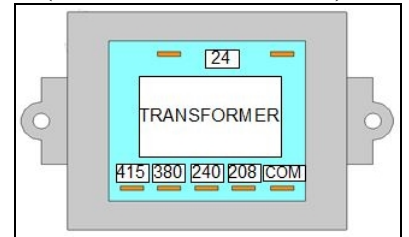

PLEASE NOTE -

- If more than one voltage is shown on the equipment's data plate, the factory default setting is usually the higher voltage on the transformer.
- As an example, a "208/230" voltage will be set to "240" from the factory.

1.3.e Schematic Location

Schematics are located on the inside of the electrical panel.

1.4 Connecting an External Controller (Optional)

To support a direct connection to an external controller, AquaCal® heat pumps are equipped with removable terminal blocks on the control board. The control board is located on the low-voltage side of the electrical enclosure.

IN THIS SECTION:

1.4.a PoolSync®	15
1.4.b 2-WIRE Controllers (Pool-Spa)	15

1.4.a PoolSync®



Select heat pumps will automatically allow for WI-FI capabilities using a PoolSync® .

- The PoolSync® device will allow direct control of the heat pump from a mobile device.
- Contact installing dealer to order this product. See "PoolSync® WI-FI Controller (ECP0343)" on page 20.
- Go online and download the PoolSync® manual for information on connecting and using this device with an AquaCal heat pump. <https://www.aquacal.com/owners-manuals/>

1.4.b 2-WIRE Controllers (Pool-Spa)

NOTICE

Failure to heed the following may result in damage to equipment.

- Confirm equipment connected to heat pump before selecting this option . All existing configurations will be cleared.

1. Deactivate power to heat pump.
2. Remove the heat pump electrical access panel.
3. Route 22-gauge (minimum), 2-conductor, low-voltage wires from the controller to the low voltage side of the heat pump's electrical enclosure. Follow all National Electric Codes (NEC) unless State or Local guidelines supersede.
4. Connect the controller wires to the control board port labeled "2WIRE" with the terminals labeled "Y" and "Z" as follows.
See Figure 1.
 - Connect one wire to "Y".
 - Connect other wire to "Z".
 - The polarity of the wire is not important.
5. Connect the 2-WIRE Enable Jumper.
6. Reattach heat pump access panel.
7. Apply power to heat pump.
8. **Set the dial on the control panel to 104° F.** This will allow the external control (2-wire) device to operate the heat pump.

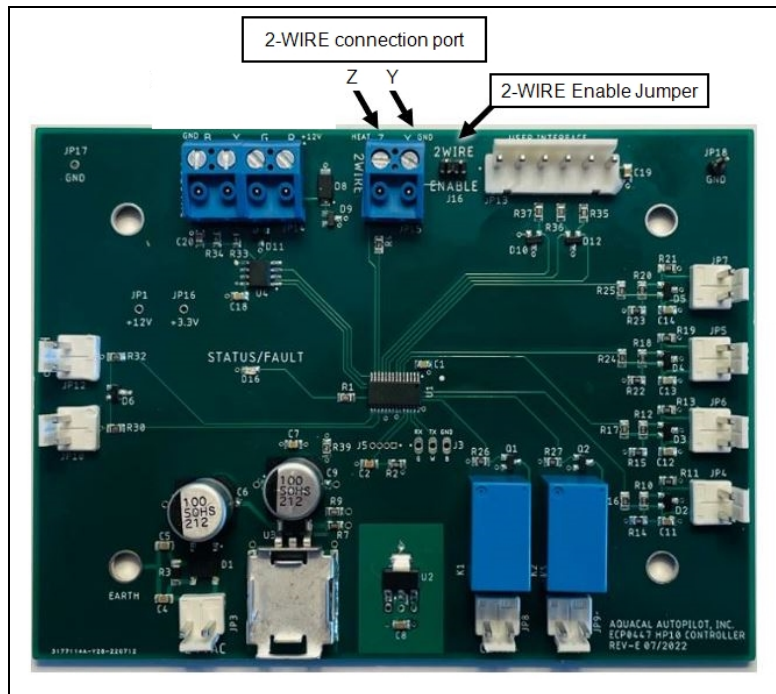

Figure 1

IN THIS SECTION:

2.1 Adjusting Water Flow Using ΔT (Delta-T)	16
2.2 Adjusting Water Pressure Switch (Select Units)	17
2.3 Available Accessories	18
2.4 Clearances	20
2.5 Dimensions	21
2.6 Identifying Model Specifications	22
2.7 Three-Phase Adjustment	24
2.8 Weights	24
2.9 Initial Heating Recommendations	25
2.10 Winterizing	25

2.1 Adjusting Water Flow Using ΔT (Delta-T)

The Delta-T is the temperature difference between the water temperatures entering and leaving the heat pump.

The equipment can be fine-tuned for maximum performance by balancing water flow rates to maintain an ideal ΔT .

The adjustment procedure must be completed with the unit in heating mode

1. Adjust the thermostat to its lowest setting with the unit in heating mode.
2. Deactivate the water filtration pump.
3. Confirm that the filters leading to the heat pump are clean.
4. Adjust the valves controlling water headed towards the heat pump to the half-open position.
5. Adjust the valves controlling water leading away from the heat pump to a fully open position.
6. Activate the pool water filtration pump.
7. Slowly raise the thermostat temperature until the heat pump activates.
 - After a four-minute delay, the heat pump's compressor will start.
8. With the heat pump running, confirm the filtration pump is operating properly with adequate flow and no short cycling.
9. Wait for water temperatures to stabilize (approximately 5 minutes).
10. Adjust valves in the following order using the temperature chart provided.
 - a. Adjust the valve that controls water exiting the heat pump until the correct temperature differential is achieved. Match the temperature measured with a temperature probe to the chart.
 - b. Wait for water temperatures to stabilize. Then check the temperature again. Re-adjust the valve as needed.
11. Mark valves at these positions for future reference.

HEAT EXCHANGER TYPE	MODEL	TEMPERATURE
Titanium ThermoLink [®]	SQ125	3° to 7° F (1.7° C to 3.9° C)
Titanium ThermoLink [®]	SQ145	3° to 7° F (1.7° C to 3.9° C)

HEAT EXCHANGER TYPE	MODEL	TEMPERATURE
Titanium ThermoLink®	SQ225	4° to 9° F (2.2° C to 5° C)
Tube-in-Tube	T035	1° to 4° F (.5° C to 2.2° C)
Tube-in-Tube	T055	2° to 5° F (1.1° C to 2.8° C)
Tube-in-Tube	T075	3° to 7° F (1.7° C to 3.9° C)
Titanium ThermoLink®	T090	3° to 6° F (1.7° C to 3.3° C)
Titanium ThermoLink®	T115	3° to 7° F (1.7° C to 3.9° C)
Titanium ThermoLink®	T135	4° to 8° F (2.2° C to 4.4° C)
Titanium Tube-in-Tube	T170	3° to 7° F (1.7° C to 3.9° C)

Table 2 - Temperature Chart

PLEASE NOTE -

- Temperature differences are based on pool water temperatures of 69° to 75° F. (20.5° to 23.8° C)
- For water temperatures outside this range, contact AquaCal®. See "*Contacting AquaCal AutoPilot, Inc.*" on page 1.

2.2 Adjusting Water Pressure Switch (Select Units)

Adjust the water pressure switch when heat pump attempts to operate without water flow.

Before attempting any adjustments confirm the following :

- The filter is clean.
- Filter pump is operating.
- The valves are set to direct the appropriate amount of water through the heat pump. See "*Water Flow Rates*" on page 9.

⚠ DANGER

Failure to heed the following will result in injury or death.

- Deactivate power while routing wiring to control board.
- Follow all National Electric Codes (NEC) and/or State and Local guidelines.

⚠ WARNING

Failure to heed the following may result in injury or death.

- Water Pressure Switch adjustment procedure to be performed by experienced service personnel only; procedure must not be attempted by individuals lacking adequate electrical and mechanical experience.

NOTICE

Failure to heed the following may result in damage to equipment.

- If the heat pump continues to operate after a water pressure switch adjustment, deactivate equipment and perform additional troubleshooting.

1. Remove heat pump access panel.
2. Locate the water pressure switch. It will be outside and along the bottom edge of the electrical enclosure. The exact location varies by model.
3. Activate the filter pump.
4. Apply power to heat pump.
5. Slowly rotate the adjustment wheel on the switch. Keep turning the wheel until the heat pump indicates it is receiving water.
6. Deactivate filter pump. If correctly adjusted, the heat pump will deactivate and the display will show "".
7. Re-install heat pump access panel.
8. If the heat pump continues to operate without water flow, the installation of a grid flow switch may be required.
 - This can become necessary if the heat pump is installed below the elevation of the body of water to be heated. The standing pressure from the water can cause the water pressure switch to activate when the circulation pump is off. Therefore a water flow switch must be used in place of a water pressure switch to determine if incoming water is being sent to the heat pump. See "*Grid Flow Switch (# 0040S)*" on the next page.
9. If the heat pump continues to operate without water flow, contact AquaCal®.

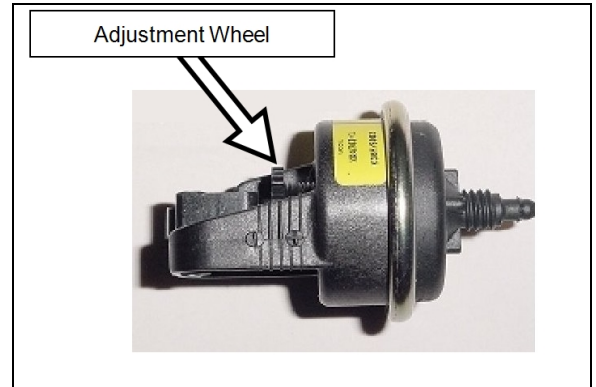

2.3 Available Accessories

Accessories may be purchased through an authorized dealer of AquaCal® products.

Bypass Valve Kit (# STK0135)

- When high flow rates are outside recommended specifications, please use this kit or an alternative bypass valve system.
- This kit can be used to control excessive water flow through the heat pump. It provides automatic flow adjustments for most applications.



Condensation Drain Kit (# STK0202)

- Used when condensation water flow must be directed to a specific location.



Grid Flow Switch (# 0040S)

- Used for automatic pool/spa thermostat switching.
- This switch can also be used in place of the water pressure switch. This may be needed when the pool/spa elevation is higher than the heat pump. A higher elevation of the water can cause a false signal to the heat pump; indicating water is flowing through the heat pump when it isn't.
- This kit is not to be used on applications exceeding 50 PSI (345 kPa).



Liquid Blankets

- An invisible liquid heat barrier designed to retain heat and extend the swimming season.
- AquaCal® recommends [Lo-Chlor®](#) Aqua Blanket™.



Over Temperature Alarm Kit

- This kit is an additional safety device. It disables the heat pump if any malfunction occurs that allows the water temperature to surpass a safe level.
- This kit is strongly recommended for all spa applications.
 - Single Phase Heat Pump - (# STK0221)
 - Three Phase Heat Pump - (# STK0222)

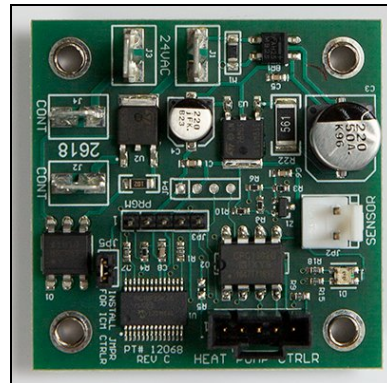

Plumbing Unions

- 2 Inch Unions - (# PLS2627)



PoolSync® WI-FI Controller (ECP0343)

- This kit will add WiFi control capabilities to the heat pump.
- Contact installing dealer to order this product.



Temperature Port Kit (# STK0096)

- This port can be used to adjust water flow using Delta-T.
- The kit comes with port, installation components, and a temperature probe.



2.4 Clearances

- Proper air circulation is required for the heat pump to operate efficiently. The following diagrams show the minimum clearances required for the proper operation of the heat pump.
- Avoid placing objects near or on top of the heat pump. This includes shrubbery and lawn furniture. These objects will reduce performance and efficiency and hinder maintenance access.

(Overhead Clearance)

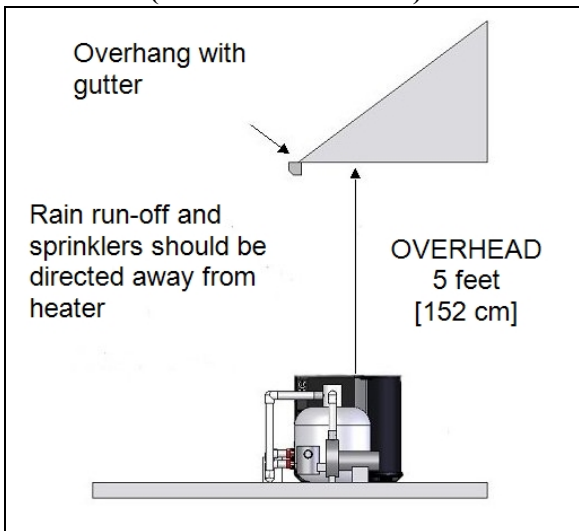

(Top View)

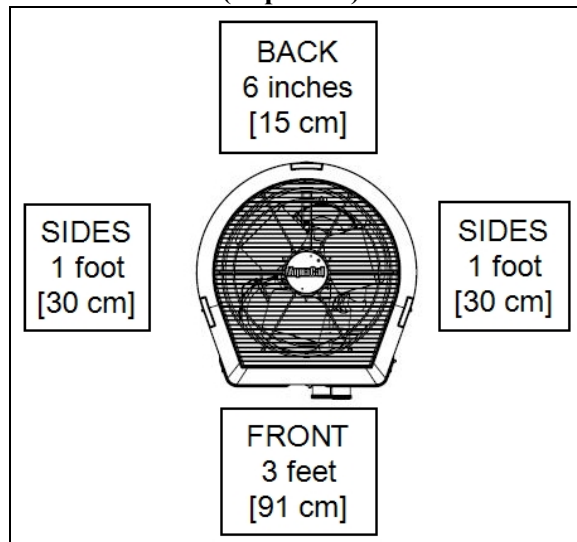

(Top View)

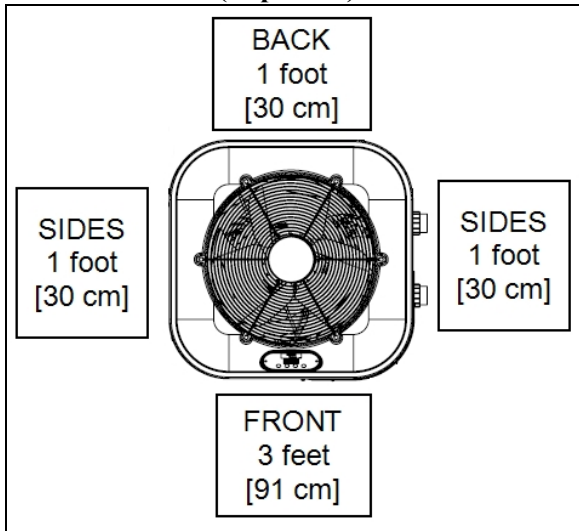

2.5 Dimensions

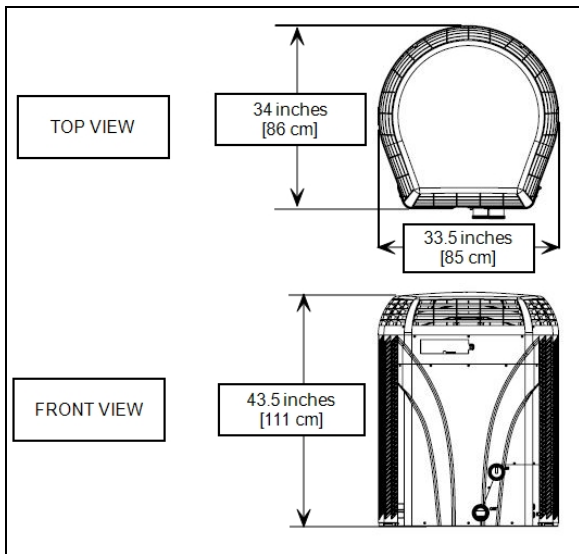

HeatWave SuperQuiet® SQ120R, SQ125, SQ145, SQ166R and SQ225

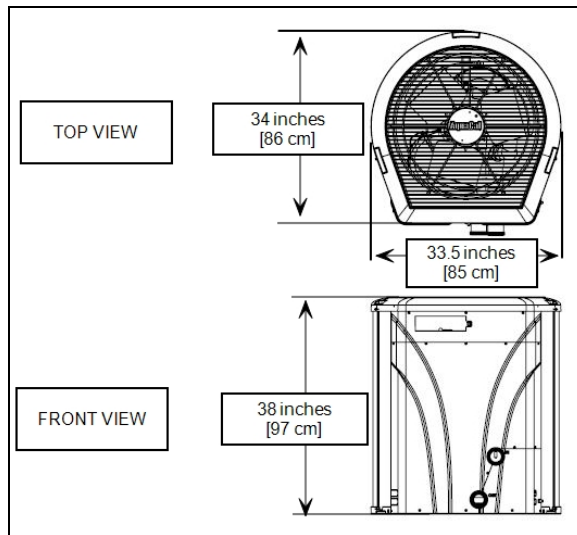

TropiCal® T090, T115, T135

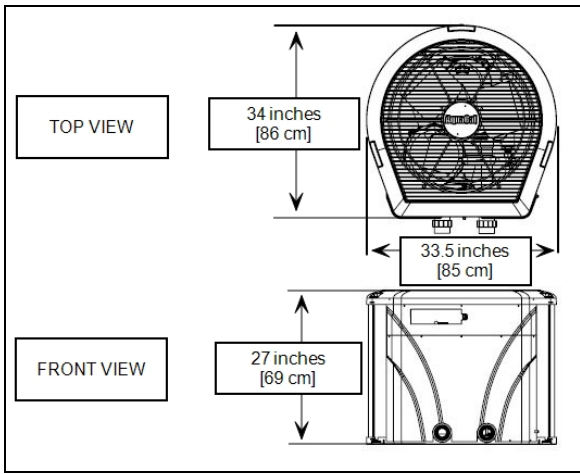

TropiCal® T035, T055, T075

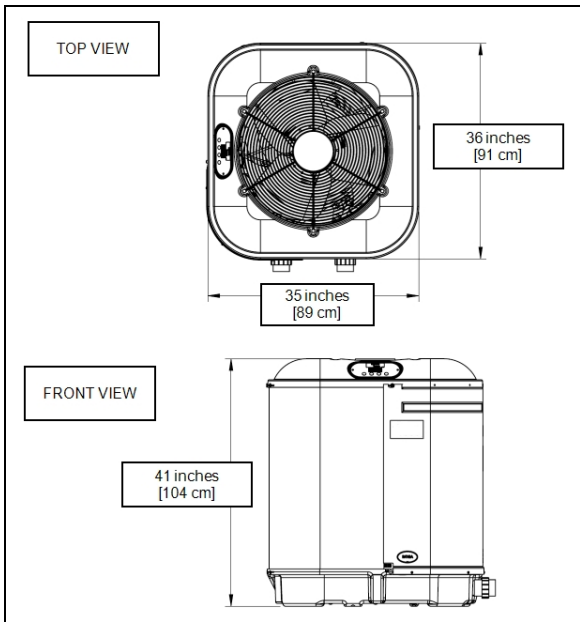

TropiCal® T170

2.6 Identifying Model Specifications

1. Find Data Plate - The data plate is usually posted on the side of the equipment or the inside of the heat pump's access plate.
2. Find the model number on the data plate. The first letters and numbers indicate the model type.
3. The complete model number identifies the equipment's specifications.

Data Plate Example

MINIMUM CIRCUIT AMPACITY	<input type="text"/>	MADE IN THE USA
ELEC. SERVICE: VOLTS	<input type="text"/>	PH <input type="text"/> HZ <input type="text"/>
MAXIMUM TIME DELAY FUSE OR HACR BREAKER	<input type="text"/>	5
COMPRESSOR VOLTS	<input type="text"/>	R.L.A. <input type="text"/> L.R.A. <input type="text"/>
FAN MOTOR VOLTS	<input type="text"/>	H.P. <input type="text"/> F.L.A. <input type="text"/>
REFRIGERANT: Circuit - Factory charged	<input type="checkbox"/>	Only oz/Kg <input type="text"/>
Tested to	<input type="text"/> psig High side /	<input type="text"/> psig Low side
AQUA CAL, INC A TEAM HORNER COMPANY 2737 24 TH STREET NORTH ST. PETERSBURG, FL 33713 FACTORY SERVICE 727-823-8642		OUTDOOR UNIT MODEL NUMBER <input type="text"/> IBAR CODE SERIAL NUMBER <input type="text"/> IBAR CODE

Model Number Example

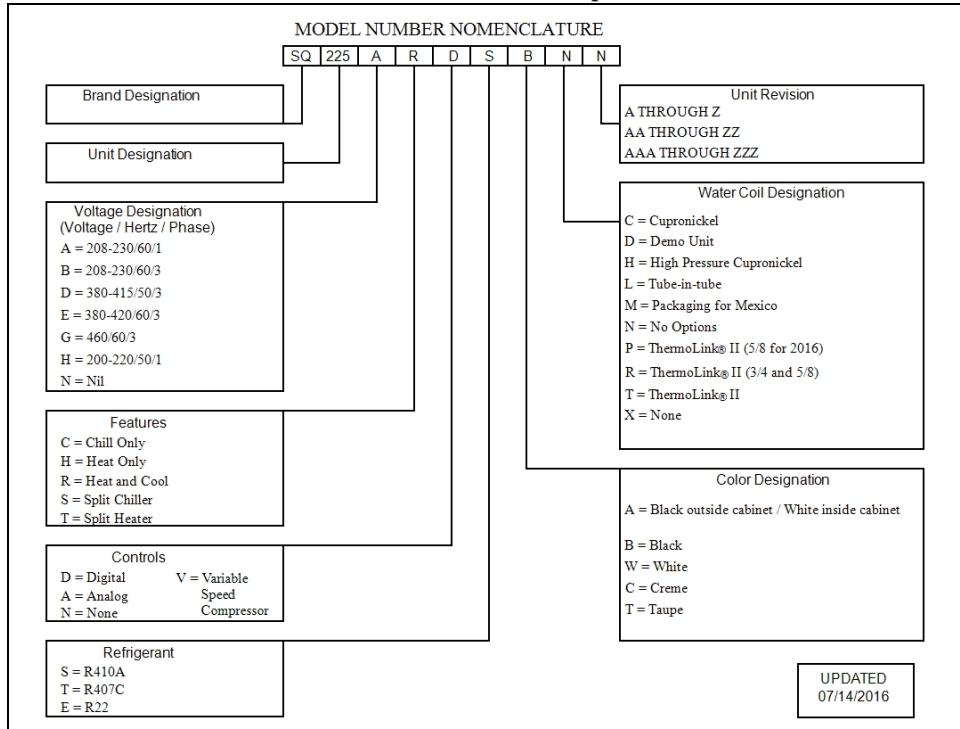

2.7 Three-Phase Adjustment

⚠ DANGER

Failure to heed the following will result in injury or death.

- Deactivate power while routing wiring to control board.
- Follow all National Electric Codes (NEC) and/or State and Local guidelines.

⚠ WARNING

Failure to heed the following may result in injury or death.

- The information contained in this section is intended for use by qualified technicians, familiar with electrical service-industry safety standards and methods.

If a three-phase unit fails to operate at start-up, the orientation of the line voltage "field" wiring may need to be adjusted.

- The phase monitor is located inside the electrical panel.
1. Deactivate power to the unit. **Confirm that power is off to all three legs using an electrical test meter set for the correct voltage.**
 2. Switch position of the incoming power wires at each leg as follows, re-connect power and attempt to restart the unit. If the unit fails to start, disconnect power. Verify off and proceed to the next leg.
 - Switch incoming power wires at L1 and L2 on the line side to the contactor.
 - Switch incoming power wires at L1 and L3 on the line side to the contactor.
 - Switch incoming power wires at L2 and L3 on the line side to the contactor.
 3. When heat pump starts, disconnect power and verify off. Then confirm all line voltage connections are securely tightened. Reconnect power.
 - If the heat pump does not start, contact AquaCal® for further assistance. See "*Contacting AquaCal AutoPilot, Inc.*" on page 1.

Three-Phase Monitor



2.8 Weights

NOTE:

Specifications subject to change.

Model Type	Model Number	Install Weight
TropiCal®	T035	180 Pounds (81.6 kg)
TropiCal®	T055	180 Pounds (81.6 kg)
TropiCal®	T075	200 Pounds (90.7 kg)
TropiCal®	T090	255 Pounds (115.7 kg)
TropiCal®	T115	259 Pounds (117.5 kg)

Model Type	Model Number	Install Weight
TropiCal [®]	T135	287 Pounds (130 kg)
TropiCal [®]	T170	326 Pounds (148 kg)
HeatWave SuperQuiet [®]	SQ125	268 Pounds (121.6 kg)
HeatWave SuperQuiet [®]	SQ145	328 Pounds (148.8 kg)
HeatWave SuperQuiet [®]	SQ225	328 Pounds (148.8 kg)

2.9 Initial Heating Recommendations

The following recommendations will reduce the amount of time required to heat a pool. **If unsure of equipment heating capability, review equipment data plate.** See "*Identifying Model Specifications*" on page 22.

1. Set circulation pump time clock to 24 hours.
2. Set the desired temperature "HEAT SETPOINT" for the water.
3. Use a pool cover or blanket to reduce heating time.
4. After the desired temperature has been reached, reset circulation pump time clock to normal time frame.

2.10 Winterizing

Failure to properly winterize the heat pump as needed may result in serious equipment damage.

DANGER

Failure to heed the following will result in injury or death.

- Deactivate power while routing wiring to control board.
- Follow all National Electric Codes (NEC) and/or State and Local guidelines.

WARNING

Failure to heed the following may result in injury or death.

- Deactivate all electrical power to heat pump before performing hard freeze procedures.

NOTICE

Failure to heed the following may result in damage to equipment.

- Failure to winterize heat pump may result in serious equipment damage. Freeze damage is not covered under the heat pump warranty.
- While the plumbing connections are in the winterized condition (not fully tightened), it is imperative that water not run through the heat pump. Loss of water through loose plumbing connections may result in damage to circulation pump, pool and spa structures, and other equipment.

Light Freeze Conditions

A light freeze is when the ambient air temperature falls below 32 degrees Fahrenheit (0° C) for less than 8 hours. Typically during light freeze conditions circulating (or moving) water will not freeze. Temporarily activate the filter pump for continuous operation during light freeze conditions.

Hard Freeze Conditions

A hard freeze is when the ambient air temperature falls below 32 degrees Fahrenheit (0° C) for more than 8 hours. In areas where this condition is prevalent and sustained, the heat pump **MUST** be winterized for hard freeze conditions. Follow the correct procedure depending on the type of heat exchanger found in the heat pump.

Titanium ThermoLink® Exchanger (with no Drain)

1. Disconnect the plumbing to the heat pump at connection unions (removal is counter-clockwise).
2. Allow water to drain completely from the heat pump. Expect to see a lot of water drain out at first, and then a small amount to continue to drain out over a long period.
3. After heat pump has fully drained, partially reconnect plumbing connection unions.
4. Winterizing is complete.
5. When ready to use the heat pump again, hand-tighten connection unions. Reconnect electrical power, and set the operating mode on the heat pump. Activate the filter pump.

No Drain

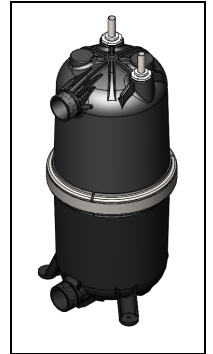

Titanium Tube-in-Tube Exchanger

1. Disconnect the plumbing to the heat pump at connection unions (removal is counter-clockwise).
2. Allow water to drain completely from the heat pump. Expect to see a lot of water drain out at first, and then a small amount to continue to drain out over a long period.

Titanium
Tube-in-
Tube

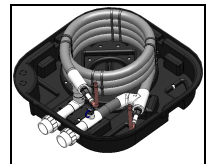

3. Place an air hose into the water inlet of the heat pump; wrap a clean rag around the hose to form a temporary seal.
4. Push all water from the water circuit using compressed air no stronger than 50 psig (446 kPa). The residual water should be forced out of the heat pump's water outlet. Allow compressed air to blow into the heat pump inlet for at least 15-20 seconds after the water stops coming out.
5. Repeat process on the outlet side of the heat pump.
6. Partially reconnect plumbing connection unions.
7. Winterizing is complete.
8. When ready to use the heat pump again, hand-tighten connection unions. Reconnect electrical power, and set the operating mode on the heat pump. Activate the filter pump.

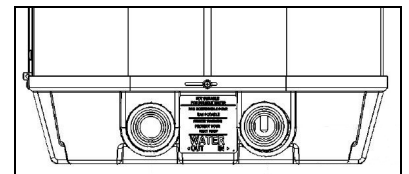

3 - Troubleshooting

IN THIS SECTION:

Fault Codes

FLOW LED is off	28
DEFROST LED is on	28
FAULT LED is rapidly blinking (Control panel unresponsive)	28
FAULT LED is blinking 1 time	28
FAULT LED is blinking 2 times	29
FAULT LED is blinking 3 times	29
FAULT LED is blinking 4 times	29
FAULT LED is blinking 5 times	29
FAULT LED is blinking 6 times	29
FAULT LED is blinking 7 times	29

Issues and resolutions

Display Panel Not Responding	30
Heat Pump Not Running	30
Heat Pump's Tripping Breaker	30
Heat Pump Won't Shut Off	31
Heat Pump Is Running, Not Heating	31
Water Coming From Heat Pump	31

3.1 Fault Codes

A fault code indicates a specific issue or condition that will require action before the equipment can resume operating.

Please perform the following troubleshooting.

If the issue reoccurs, please contact AquaCal. See "*Contacting AquaCal AutoPilot, Inc.*" on page 1.



WARNING

Failure to heed the following may result in injury or death.

- Repairs must not be attempted by untrained or unqualified individuals.
- The heat pump contains refrigerant under high pressure. Repairs to the refrigerant circuit must not be attempted by untrained or unqualified individuals. Service must be performed only by qualified HVAC technicians. Recover refrigerant before opening the system.

NOTICE

Failure to heed the following may result in damage to equipment.

- Service by unauthorized personnel will void the heat pump warranty.

FLOW LED is off

ISSUE

Low or no water detected.

RESOLUTION

1. Confirm the filter pump is on.
2. If a multiple-speed filter pump is being used, run at a higher speed to determine if the error persists. Do not exceed the maximum flow rate for your model.
3. Confirm water is not being diverted away from the heat pump.
 - See "*Water Flow Rates*" on page 9.
 - See "*Adjusting Water Flow Using ΔT (Delta-T)*" on page 16.

DEFROST LED is on

ISSUE

The heat pump has sensed the evaporator coil is icing up.

RESOLUTION

PASSIVE DEFROST

When ice starts to form on the coil, the compressor will stop operating while the fan continues to operate.

- When the coil's temperature rises above 38° F, the compressor is restarted and heating or cooling resumes.
- If the coil's temperature remains below 38° F, the compressor will remain off.

FAULT LED is rapidly blinking (Control panel unresponsive)

ISSUE

The heat pump firmware needs to be reloaded on the control board.

RESOLUTION

1. If the heat pump is connected to a PoolSync® WI-FI controller and is connected to the internet, the heat pump will automatically perform a firmware recovery.
2. If no PoolSync® WI-FI controller is connected, the heat pump will require service from a qualified technician.

FAULT LED is blinking 1 time

ISSUE

The refrigerant system's high-pressure or low-pressure switch is showing as open.

RESOLUTION

Determine if an insufficient amount of water is being supplied to the equipment.

1. Confirm the filter pump is on.
2. If a multiple-speed filter pump is being used, run filter pump at a higher speed. Do not exceed maximum flow rate for the model.
3. Confirm water is not being diverted away from the heat pump.
 - See "*Water Flow Rates*" on page 9.
 - See "*Adjusting Water Flow Using ΔT (Delta-T)*" on page 16.
4. The water pressure switch may be incorrectly calibrated. See "Adjusting Water Pressure Switch" for more information.

FAULT LED is blinking 2 times**ISSUE**

The heat pump has locked due to five high-pressure or five low-pressure faults during one call for heating or cooling.

RESOLUTION

1. Deactivate power to heat pump, wait five seconds, then reactivate power to the heat pump to clear error.
2. Troubleshoot the high-pressure issue causing the error. See "*FAULT LED is blinking 1 time*" on the previous page.

FAULT LED is blinking 3 times**ISSUE**

Incoming water temperature exceeded 110° F and the unit is locked with a high temperature fault. The heat pump will not operate until incoming water temperature drops to 100° F or lower.

RESOLUTION

1. Determine if another heat source (gas heater, solar heater, etc.) is heating water being sent directly to the heat pump. This situation will need to be corrected before continuing.
2. Rule out an incorrect reading from the water temperature sensor. Verify existing water temperature with an accurate thermometer. If heat pump's sensor is inaccurate, the water temperature sensor may require replacement.

FAULT LED is blinking 4 times**ISSUE**

Shorted or open water sensor 1.

RESOLUTION

A qualified technician should replace the water sensor.

FAULT LED is blinking 5 times**ISSUE**

Shorted or open water sensor 2.

RESOLUTION

A qualified technician should replace the water sensor.

FAULT LED is blinking 6 times**ISSUE**

Shorted or open defrost sensor 1.

RESOLUTION

A qualified technician should replace the defrost sensor.

FAULT LED is blinking 7 times**ISSUE**

Shorted or open defrost sensor 2.

RESOLUTION

A qualified technician should replace the defrost sensor.

3.2 Issues and Resolutions



WARNING

Failure to heed the following may result in injury or death.

- Repairs must not be attempted by untrained or unqualified individuals.
- The heat pump contains refrigerant under pressure. Repairs to the refrigerant circuit must not be attempted by untrained or unqualified individuals. Service must be performed only by qualified HVAC technicians. Recover refrigerant before opening the system.

NOTICE

Failure to heed the following may result in damage to equipment.

- Service by unauthorized personnel will void the factory warranty.

Please perform the following troubleshooting.

For further assistance, please contact AquaCal. See "*Contacting AquaCal AutoPilot, Inc.*" on page 1.

Display Panel Not Responding

1. If the heat pump is controlled by an external controller, confirm the external controller settings. See "Operating Heat Pump (With an External Controller)".
2. If the issue is still occurring, disconnect external controller from the heat pump. Then check operation at heat pump.
 - If display panel responds, the problem lies with the external controller or its installation. Contact the manufacturer of the external control device.

Heat Pump Not Running

1. Confirm equipment is receiving power. Is the heat pump display illuminated?
 - If not, confirm the main breaker (located at the power supply panel) and the disconnect switch (located near the heat pump) are both turned on.
 - Confirm the power switch on the heat pump's display is set to on.
 - If the display still does not illuminate, it is recommended that the heat pump installer or electrician confirms heat pump is receiving power.
2. Confirm thermostat is set correctly. See "Dial Control Panel".
 - When heating the water is desired, the thermostat should be set above the current water temperature.
3. If an error code is displayed, diagnose and correct the cause of the code. See "*Fault Codes*" on page 27.
4. If the heat pump is using an external controller, the heat pump may not be set correctly at the external controller.
 - See "Operating Heat Pump (With an External Controller)".

Heat Pump's Tripping Breaker

1. Have an electrician confirm breakers are in good condition and properly sized for the heat pump.
2. Multiple heat pumps installed at the same site may benefit from special automatic sequencing controllers to avoid excessive power drops at start-up. See "Automatic Sequencing Controller" on page 1 for more information.
3. If a fault occurs immediately when the compressor starts, a qualified technician should evaluate the system.

Heat Pump Won't Shut Off

1. Confirm the heat pump has reached the desired temperature set on the thermostat. The heat pump will continue to run until the set temperature is reached.
2. If the heat pump is using an external controller, it may not be set correctly.
 - See "Operating Heat Pump (With an External Controller)".

Heat Pump Is Running, Not Heating

1. If the heat pump is using an external controller, confirm it is set correctly.
 - See "Operating Heat Pump (With an External Controller)".
 - If the heat pump is still not running correctly with this device, contact the installer of the external controller device or the device's manufacturer for further assistance.
3. Confirm thermostat is set to the desired water temperature.
4. Confirm valves are correctly positioned to heat the correct body of water (either the pool or the spa). If heating a spa that overflows into a pool, confirm the spa is isolated when being heated (not flowing into the pool).
5. Confirm heat pump is transferring heat into the water.
 - Measure the temperature of air discharge coming out of the heat pump fan. If discharge air is between 8° to 10° colder than the outside ambient air, the heat pump is moving heat into the water.
6. If an error code is displayed, diagnose and correct cause of code. See "*Fault Codes*" on page 27.
7. Confirm that filter pump has a sufficient run-time. The heat pump will not run (or heat the water) without water flow. Heat Pump equipment will generally be set to run 24 hours a day in commercial applications. See "*Initial Heating Recommendations*" on page 25.
8. If heating a spa, deactivate air blower or venturi (if equipped) to allow for quicker heating times. For pools, deactivate water features, such as slides, waterfalls, or fountains to allow water to retain heat. Use of a liquid pool blanket product can also compensate for excessive heat loss.
 - See Available Accessories on page 18. for more information on liquid blankets.

Ice forming on the heat pump

When conditions are too cold for proper operation, the heat pump will enter a defrost mode. This prevents ice from building up on the evaporator coil.

- The heat pump may develop a fine layer of white frost on the outside coil before entering the defrost mode. This is normal.
- If heavy ice (not frost) starts to build up, shut off the heat pump. Contact the installer or manufacturer.
- If the ambient air temperature will be falling below 32° F for more than 8 hours, winterize equipment.

Water Coming From Heat Pump

The water may be normal condensation produced as a by-product of the heat pump's refrigeration process. The heat pump can produce 8 to 10 gallons of condensation per day depending on the humidity of the ambient air. Determine if the water is condensation or a possible leak.

1. Deactivate heat pump, leaving the filter pump on. After several hours, determine if water is still coming from the heat pump.
2. If using chlorine or bromine as a pool / spa sanitizer, test the water around the heat pump using a test strip. If the test strip indicates that chlorine or bromine is present, a leak may exist.

PLEASE NOTE -

If desired, a kit is available to re-direct condensation water away from the heat pump. See "Condensation Drain Kit (# STK0202)" on page 18.

